

evolIS

Identify what matters



Agilia

USER GUIDE

Evolis © 2023. All rights reserved

user-guide_R02_ENG_202309_A1



Table of Contents

1. GENERAL INFORMATION	
Copyrights and Trademarks	5
Warranty	5
Environmental information and end of life product	5
Indications	5
About the printer	6
2. PRODUCT PRESENTATION	
Unpacking	8
Product Description	9
3. INSTALLATION, PRINT SETTINGS, PRINTING AND COMMUNICATION	
Installation	12
Location	12
Electrical connection	13
Printing ribbon and retransfer film	14
Cards	19
Installing Evolis Premium Suite 2	23
Installing cardPresso	23
Connecting to a network (Optional)	24
Print Settings and Printing	25
Managing Print Settings in Evolis Premium Suite 2	25
Starting with cardPresso	26
Interacting with the printer	27
LCD Touchscreen	27
Evolis Premium Suite 2 Notifier	28
4. OPTIONS	
Dual side printing activation key	29
Card Lamination Module (available in the first quarter of 2024)	31



Table of Contents

Installing the infrared kit on the printer	31
Installing the Card Lamination Module	31
Installing the lamination film	33
Interacting with the Card Lamination Module	34
Using the levelers	37
Encoding options	38
Magnetic encoding	38
Contact encoding	40
Contactless encoding	41
Security options	42
Kensington lock	42
Electromechanical locking system (available in 2024)	42
5. MAINTENANCE	
Replacing a printing ribbon or retransfer film	43
Remove the printing ribbon or retransfer film	43
Install the new printing ribbon or retransfer film	44
Cleaning procedures	44
Regular cleaning	45
Advanced cleaning	48
Specific cleaning	50
Cleaning the Card Lamination Module	51
6. ASSISTANCE	
Diagnostic Assistance	52
Printing a technical test card	52
Printing a graphical test card	53
Identifying installed software versions	53
Troubleshooting	54
Printing Problems	54
Jammed Cards	56
Updating the Printer Firmware	57



Table of Contents

Updating the Printer Driver	57
Technical Support	58

57

58



1. GENERAL INFORMATION

Copyrights and Trademarks

Evolis © 2023. All rights reserved.

Users must observe the copyright regulations applicable in their country. This document must not be photocopied, translated, reproduced or transmitted, in whole or in part, for any reason and by any electronic or mechanical means whatsoever without the express written consent of Evolis.

All the information contained in this document is subject to change without prior notice.

Evolis cannot be held liable for any errors that may be found in this manual, or for any loss or damage arising accidentally or as a result of dissemination or use of this manual.

All Evolis printer models, Evolis Premium Suite 2 and Evolis High Trust® are trademarks of Evolis. All other trademarks belong to their respective holders.

Warranty

Refer to the warranty booklet available on www.evolis.com > **Support section** > **Product page** to know the warranty terms, conditions and limitations.

Register your product on www.evolis.com > **Support section**.

Environmental information and end of life product

Evolis is committed to helping the environment by reducing the energy consumption of its products.

The manufacture of this product required the extraction and use of natural resources. It may contain materials that are hazardous to health and the environment. To prevent the dispersal of such materials, use existing collection systems. For more information on collection, re-use and recycling systems, contact your local or regional waste management body.

A tutorial is available on www.evolis.com > **Support section** > **Product page** to take ribbons apart and facilitate recycling.

Indications

- Indicates that failing to take the recommended action is liable to damage the printer.
- Information providing further details or depth about specific points in the main text.
- ▶ Video(s) of the procedure(s) available on www.evolis.com > **Support section** > **Product page**.



About the printer

This product uses consumables and accessories available on www.evolis.com > **Consumables**.

For more information on the technical specifications of the product and all options available, go to www.evolis.com > **Product page**.



Read this manual carefully and follow the instructions.

Comply with the instructions given in this manual to ensure a good functioning of the printer.

The manufacturer's warranty is subject to a strict compliance with the routine servicing and maintenance instructions, and in particular the printer cleaning cycles.

Any failure to follow the maintenance and servicing procedures voids the print head warranty.

Icons on the printer label:



Evaluation for apparatus only based on altitude not exceeding 2000m, therefore it's the only operating condition applied for the equipment. There may be some potential safety hazard if the equipment is used at altitude above 2000m.



Evaluation for apparatus only based on temperate climate condition, therefore it's the only operating condition applied for the equipment.

There may be some potential safety hazard if the equipment is used in tropical climate region.



Reminder to use existing collection facilities.



The heating roller may be hot

Certifications and declaration of conformity

- CE, UKCA, ICES, VCCI, BIS, EAC, ROHS
- FCC (Evolis contact: Evolis, Rising Sun Mills, 188 Valley St., Suite 421, RI 02909 Providence, evolisnortham@evolis.com)

Dimensions and weight

- 445x373x205 or 538x373x205 (with rear box) (H x W x D)
- 9,5kg



Connectivity

- USB 2.0
- USB A (internal USB hub): 1 port
- USB B : 1 port
- Ethernet: TCP-IP 10Base T, 100Base T (Traffic LED)
- Wi-Fi (option)

Environment conditions

- Standard operating temperature: 15° / 30° C (59° / 86 °F)
- Max/min operating temperature and humidity rate: 15° / 30°C (59° - 86°F) and 20% to 65% non condensing
- Max/min storage temperature and humidity rate: -5° / +70° C (23° / 158° F) and 20% to 70% non condensing
- Operating ventilation: Free air

Electrical information

- Power supply: AC90 - 125V, 220-240V, 50-60Hz
- Printer: 100-240 Volts AC, 50-60 Hz, 2A / 24 Volts DC, 6,25 A / 150W



2. PRODUCT PRESENTATION

Unpacking

- The printer is shipped in a packaging designed to prevent damage in transit. If visible damage is noticed when unpacking the product, contact the shipper and immediately inform your Evolis reseller, to know the procedure to follow.
- The full original packaging (outer box, inner wedges and protective bags) is required in the event that the printer is returned. Keep the packaging somewhere clean and dry. If the printer is returned without its original packaging and components are damaged during transit, these components are no longer covered by the warranty. You will be charged for new packaging for shipping the printer back to you.
- If any of the accessories is missing, contact your Evolis reseller.
- Use only the power supply unit and USB cable supplied with the product.
- The printer must be placed in a dry location, protected from dust and drafts but well-ventilated.
- Make sure to keep the printer on a flat surface able to bear its weight.
- A step by step tutorial to install the product is available on www.evolis.com > **Support section** > **Product page**.

Accessories supplied with your printer:

- Power supply unit FSP type FSP150-AAAN3
- Main power cable
- USB cable
- Starter cleaning kit
- Quick installation guide with QR code to access the driver
- Licence activation card for cardPresso designing software



Product Description

- Access to the side panels of the machine and the option module fitting/removal areas is restricted to a retailer/installer or to experienced users.
- Always disconnect the machine from the power supply (unplugged) before performing work on it.
- If the printer is equipped with an LCD Touchscreen, refer to the corresponding user guide available on www.evolis.com > **Support section** > **Product page** for more information.

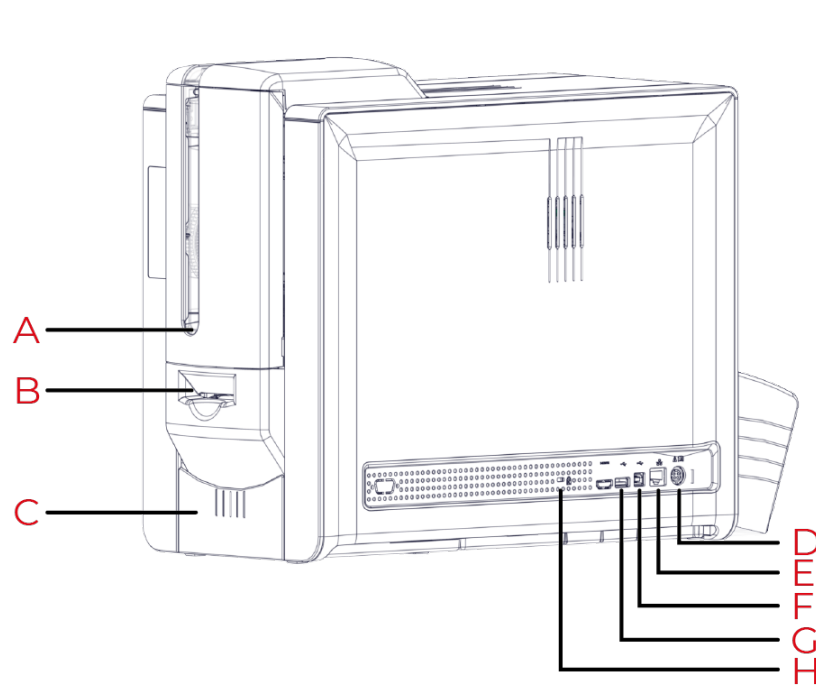

- A. Card feeder
- B. Manual card feeder (insertion / ejection)
- C. Front output box
- D. Power cable connector
- E. Ethernet connector
- F. USB socket (type A)
- G. USB socket (type B)
- H. Location for the Kensington locking system

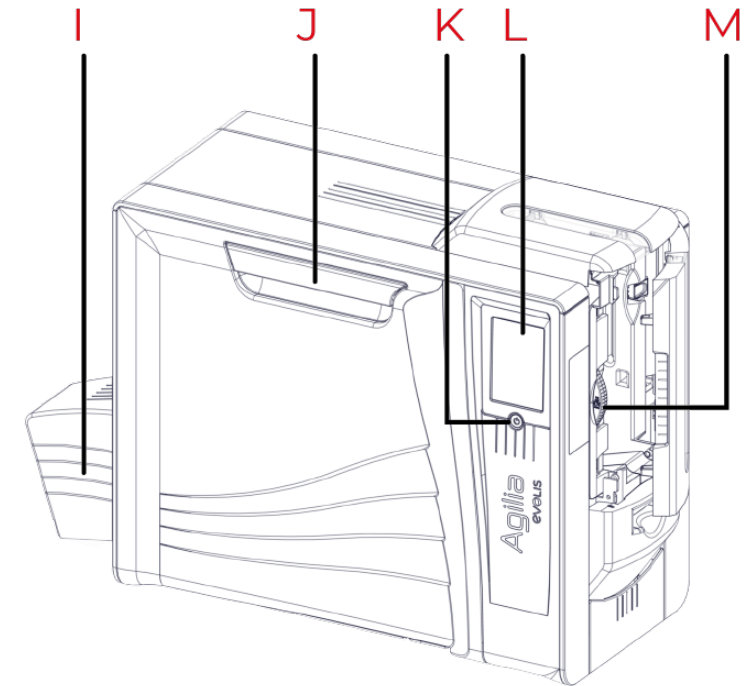

- I. Rear output box
- J. Front door opening mechanism
- K. Power button
- L. LCD Touchscreen
- M. Card thickness selector



- N. Rear output
- O. Location for the infra-red kit

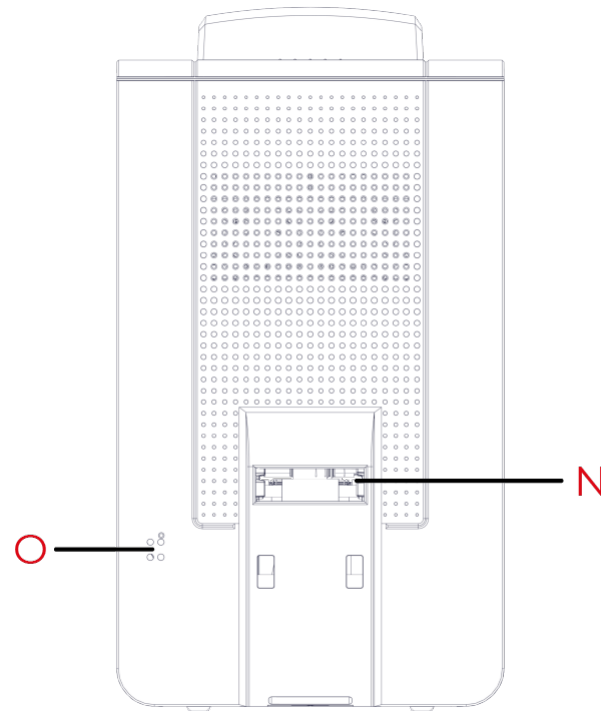

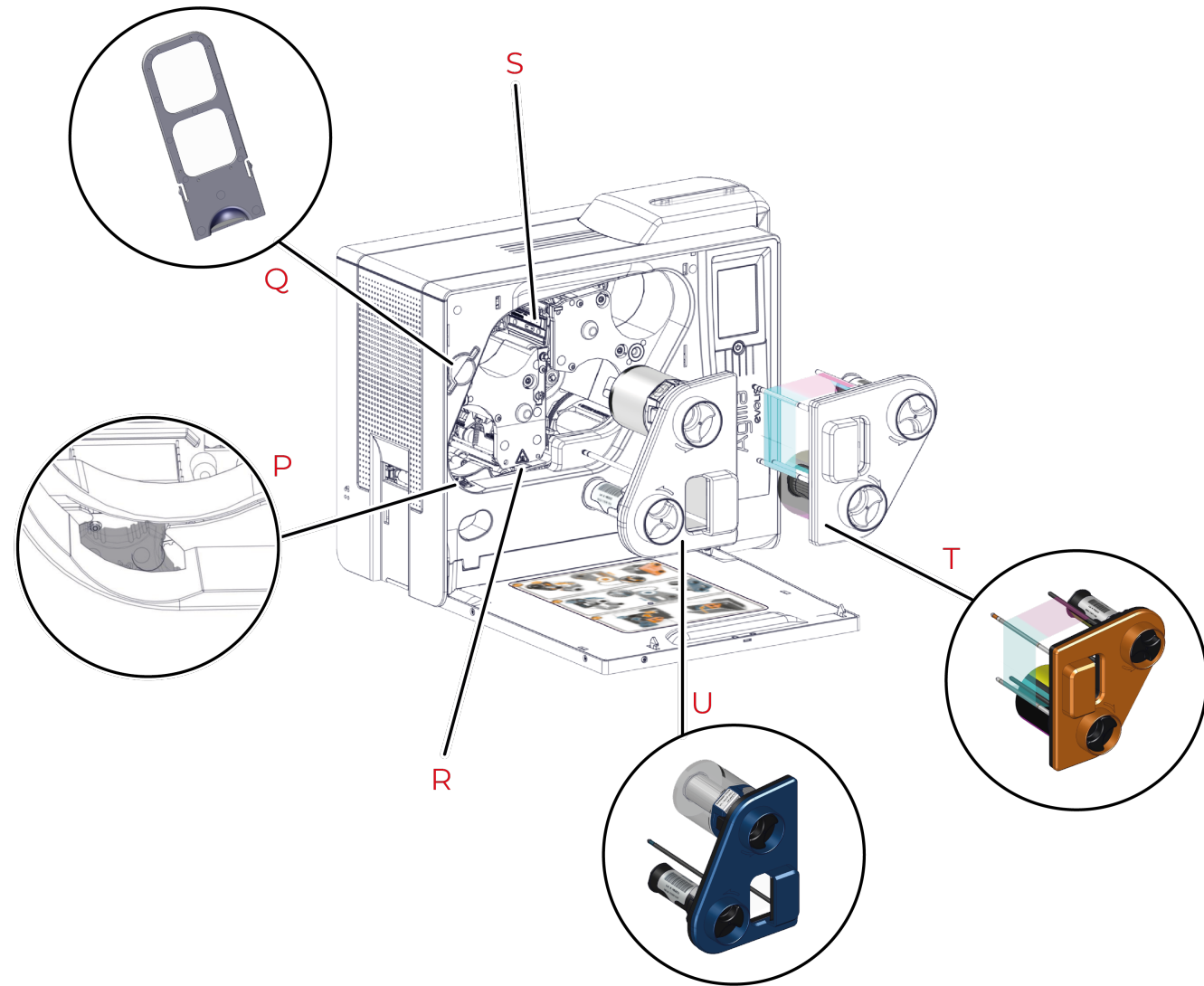

- P. Jam-clearing wheel
- Q. Dust filter
- R. Heating roller
- S. Print head
- T. Cassette for the printing ribbon
- U. Cassette for the retransfer film



3. INSTALLATION, PRINT SETTINGS, PRINTING AND COMMUNICATION

Installation

Location

- Install the equipment on a flat surface able to bear its weight.
- Install the printer where the airflow is not obstructed to ensure the proper function of the fans and cooling of the printer.
 - Avoid putting rear and left sides of the printer against a wall or any solid surfaces.
 - Leave at least 10cm between a solid surface and the rear and left sides of the printer.

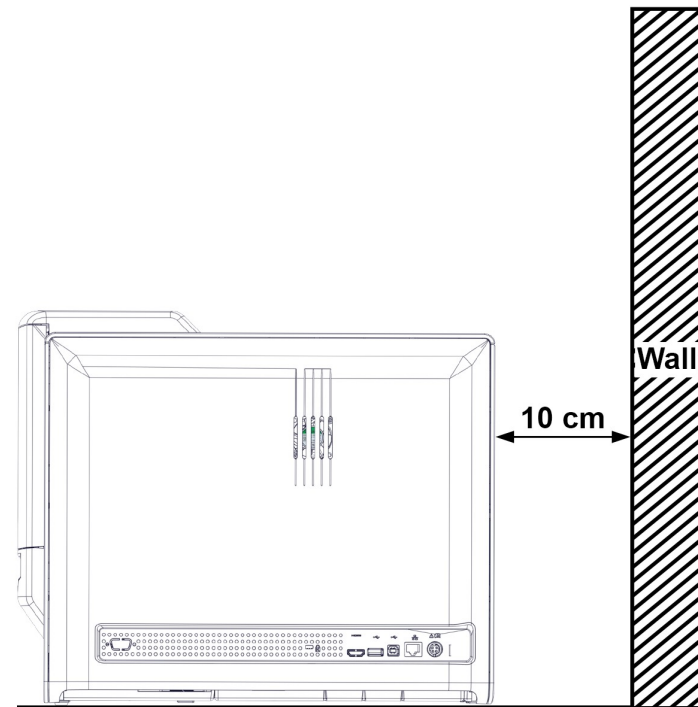
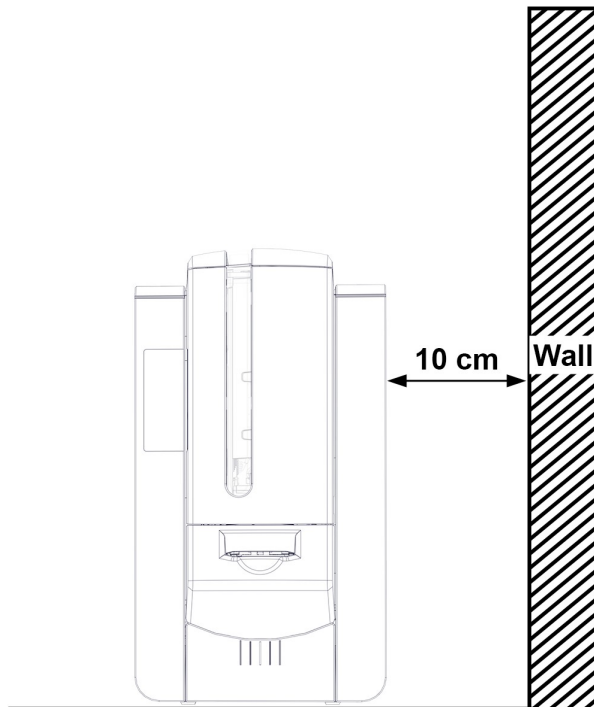



Electrical connection

- The printer must be connected to a properly protected and earthed electrical installation.
 - FI: Laite on liitettävä suojamaadoitus koskettimilla varustettuun pistorasiaan.
 - NO: Apparatet må tilkoples jordet stikkontakt.
 - SE: Apparatens skall anslutas till jordat uttag.
 - DK: Printerens skal tilsluttes til en korrekt beskyttet og jordforbundet el-installation.
 - Before attempting maintenance, unplug the power supply cable from the printer.
 - For your personal safety, the power supply cable and unit must remain easy to access, especially in case of emergency.
- To save energy, the printer automatically goes to standby mode after 3 minutes of inactivity. The printer goes to hibernation mode after 10 minutes in standby mode.
- Standby and hibernation settings can be configured in the print center, Evolis Premium Suite 2 or from the LCD Touchscreen. In standard standby mode, sending a print request restarts the printer and pressing the power button (for 1 second) exits the printer from hibernation mode.

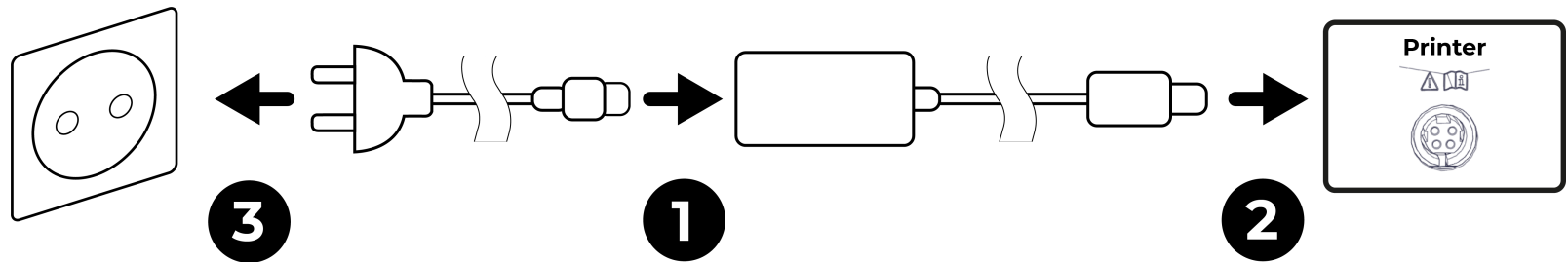

- 1 Connect the power cable to the power supply unit.
- 2 Plug the power supply unit connector into the printer.
- 3 Plug the end of the power cable into an earthed power socket.

The printer is powered on: the control panel lights up showing the printer is working properly.

If the printer is not showing a **Ready** status, check the installation.

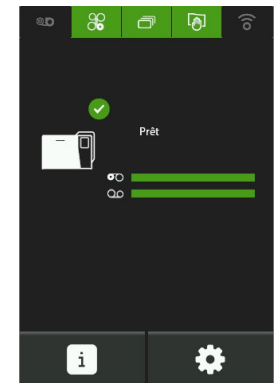



Printing ribbon and retransfer film

- Only use Evolis High Trust® consumables. These consumables insure printing quality, reliability and maximize the life span of the print head. The use of consumables other than Evolis High Trust® may lead to a bad printing quality and a dysfunction of the card printer.

Manipulating the cassettes

When manipulating the printing ribbon, the retransfer film and the cassettes:

- Always put the cassettes on a flat surface with their pins facing up.

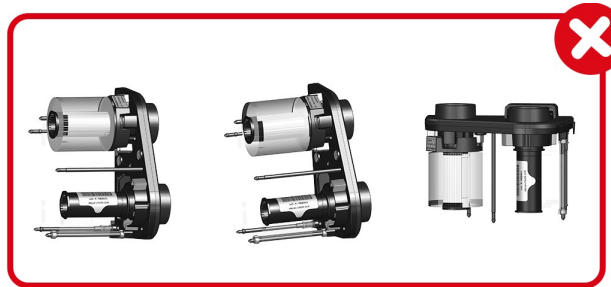
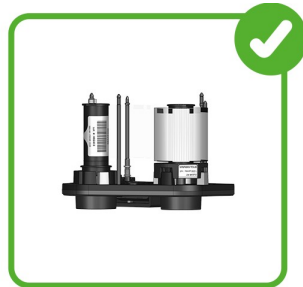

- Do not grab the cassettes by the pins. It may result in the bending of the pins and printing quality issues.
- Avoid dropping the cassettes. It may damage the pins and result in insertion difficulties or print quality issues.
- Avoid touching the printing ribbon and retransfer film with your fingers.



Installing the printing ribbon and retransfer film

- An installation procedure is available inside of the door of the printer.
- The cassettes are color coded to facilitate and prevent mistakes during installation. The blue cassette is for the retransfer film and the orange cassette is for the printing ribbon.

Remove the cassettes

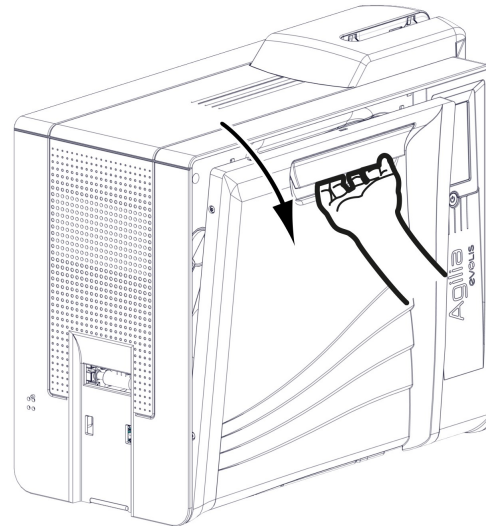

1. Open the door of the printer.

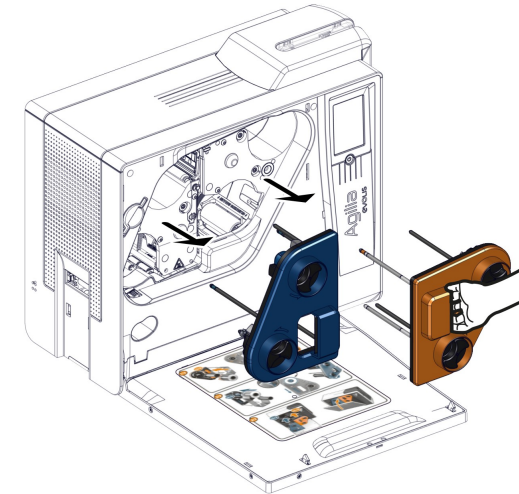

2. Pull the cassettes out of their compartments.
3. Put them on a flat surface with the pins facing up.



Install the printing ribbon

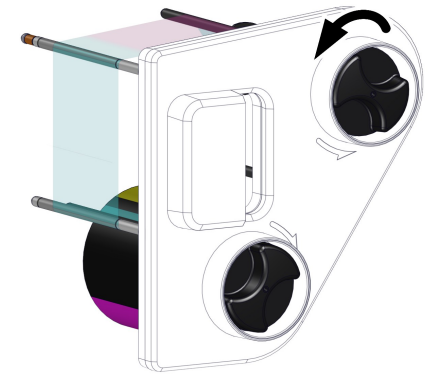
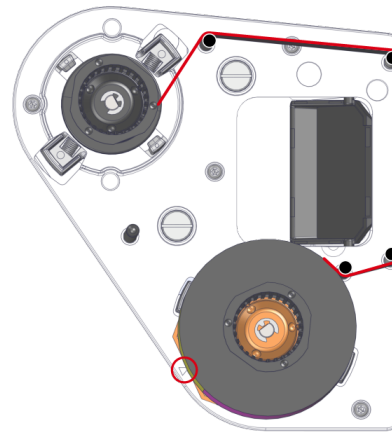
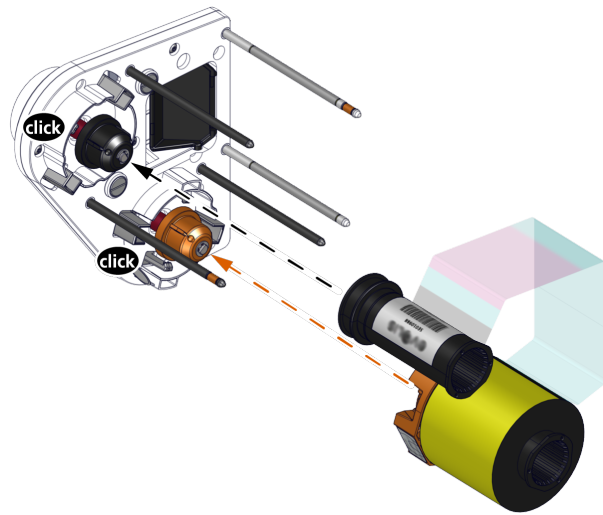

4. Take the printing ribbon.
5. Insert the start (full) roll of the ribbon on the orange spindle. The ribbon unwinds upward. A click confirms the correct insertion. The etiquette on the side of the ribbon base must point to the arrow.
6. Put the ribbon around the pins.
7. Insert the finish (empty) roll of the film on the black spindle.
8. Use the wheel on the outside of the cassette to tighten the ribbon, following the direction of the arrows (one complete turn).



Install the retransfer film

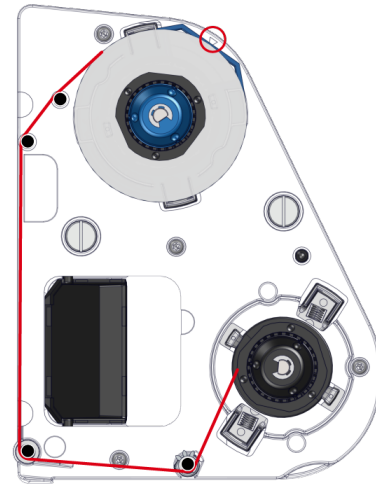
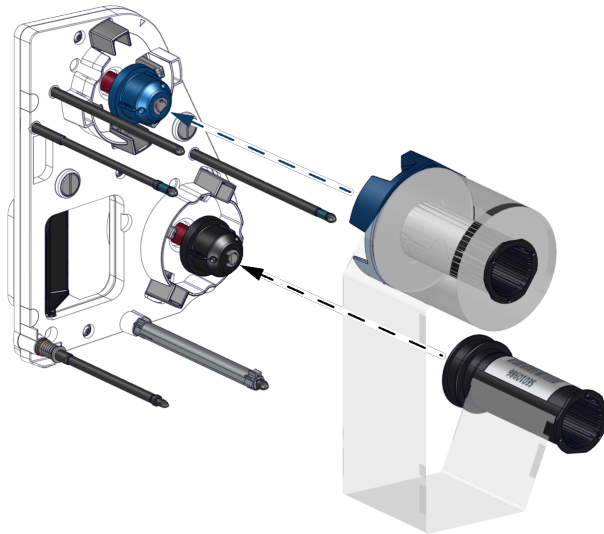

4. Take the retransfer film.
5. Insert the start (full) roll of the film on the blue spindle. The film unwinds downwards. A click confirms the correct insertion. The etiquette on the side of the ribbon base must point to the arrow.
6. Put the film around the pins.
7. Insert the finish (empty) roll of the film on the black spindle.
8. Use the wheel on the outside of the cassette to tighten the ribbon, following the direction of the arrows (go to the second set of black marks).



Put the cassettes back in place

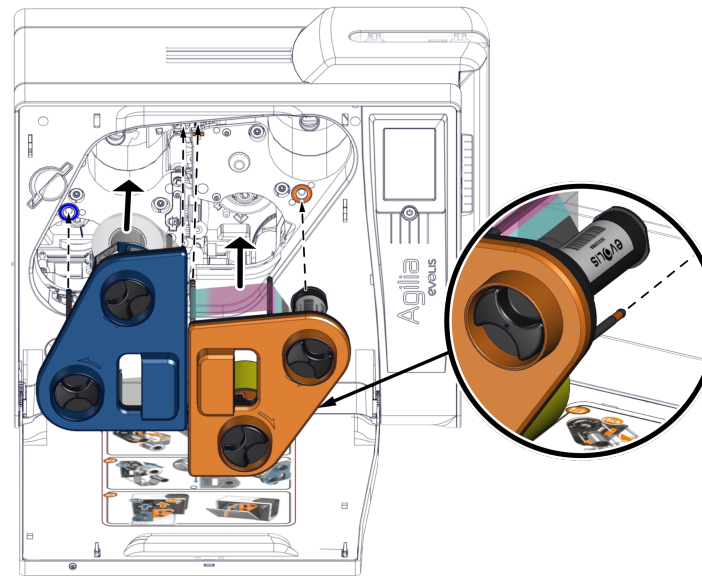

9. Take the cassettes and insert them in their locations following the color guides.
10. Press on the upper right corner of the blue cassette to properly install it. A click confirms the correct installation.
11. Press between the tightening wheels of the orange cassette to properly install it. A click confirms the correct installation.
12. Close the door.



Cards

- For optimum quality, the cards used must be ISO 7810 certified.
- Use only the card types recommended by Evolis.
- Do not touch the printable surface of the cards to preserve print quality.
- Do not use cards that are damaged, folded, embossed or dropped on the floor.
- Keep your cards protected from dust.
- **Smartcards** used for **magnetic encoding** must be inserted with the stripe facing down.
- **Smartcards** used for **contact encoding** must be inserted with the chip facing upwards.

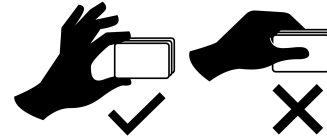

Adjusting card thickness

- Card thickness can be set from 0.76 mm – 30mil to 1.25mm - 50mil.
- Factory setting of the printer is 0.76 mm – 30mil.

1. Open the card feeder.
2. Use the card thickness selector to set the thickness according to the thickness of the cards being used.
3. Close the card feeder.

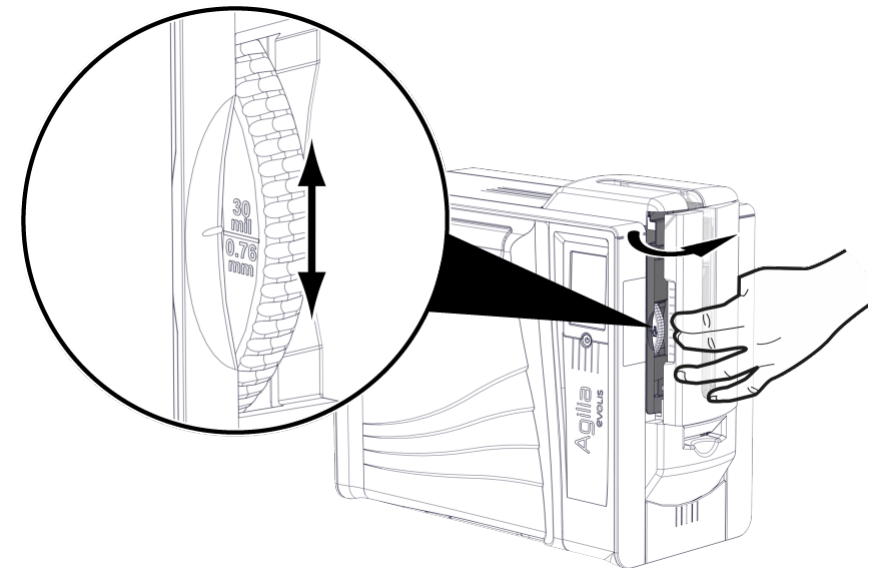



Loading cards in the card feeder

- The card feeder has a total capacity of 200 cards (0.76 mm – 30mil).

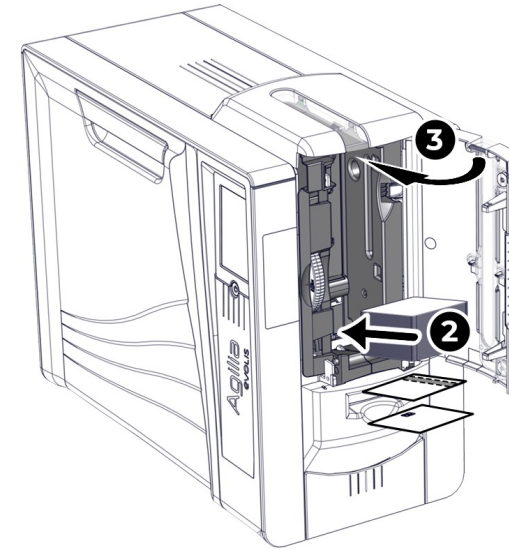
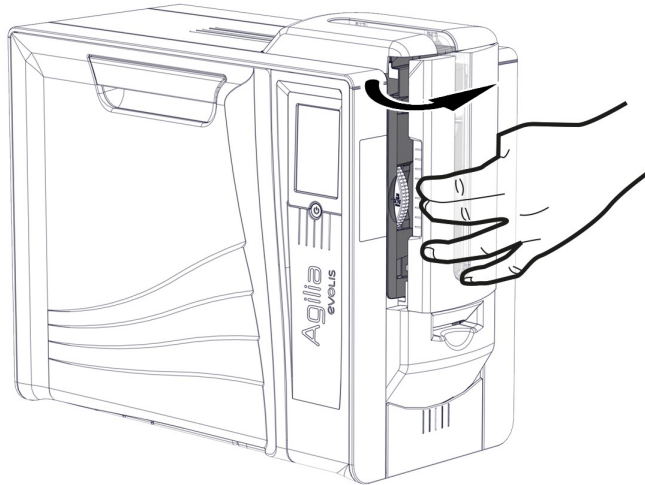

1. Open the card feeder.

2. Load cards.

3. Close the card feeder.

Manual card feeding

- The card input can be specified in **Evolis Premium Suite 2 > Printer settings > Printing > Card > Card input/output > Card input**.
- Manual insertion must be selected to feed one card at a time to the printer.

The printer is equipped with a manual card feeder (Bezel) located between the card feeder and the reject box (see [Product Description](#)^{୨୩}).

1. Set the card input in the Evolis Premium Suite 2.

2. Insert a card into the bezel. The card is taken by the printer and printing starts.



Installing the rear output box

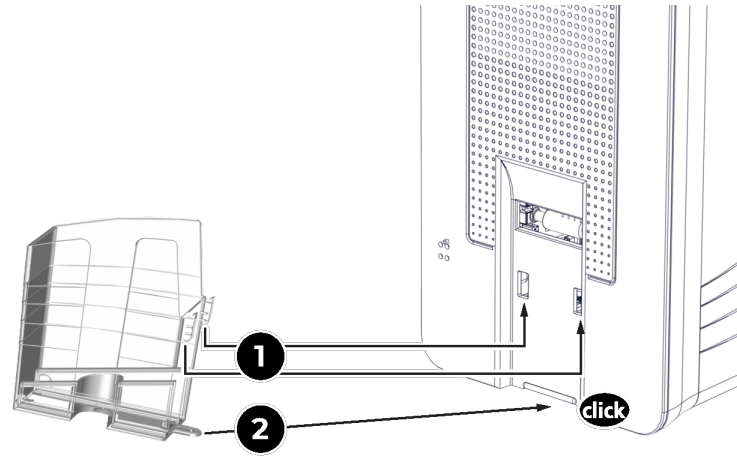

1. Insert the 2 upper clips of the box in the notches on the rear of the printer.
2. Push the box against the printer to slide the bottom clip under the printer. A click confirms the correct installation.

Removing Printed Cards

- By default, the printed cards are ejected in the rear output box and the error cards are ejected in the front output box.
- The card output can be specified in **Evolis Premium Suite 2 > Printer settings > Printing > Card > Card input/output > Card output**.
- The options are:
 - Output hopper (rear output box)
 - Reject box (front output box)
 - Manual ejection (Bezel)

Cards are ejected in the rear output box

- The rear output box has a total capacity of 100 cards (0.76 mm – 30mil).
1. If the rear output box is supplied with a cover, pull the cover backwards.
 2. Collect the cards using the side opening.



Cards are ejected in the front output box

- The front output box has a total capacity of 10 cards (0.76 mm – 30mil).

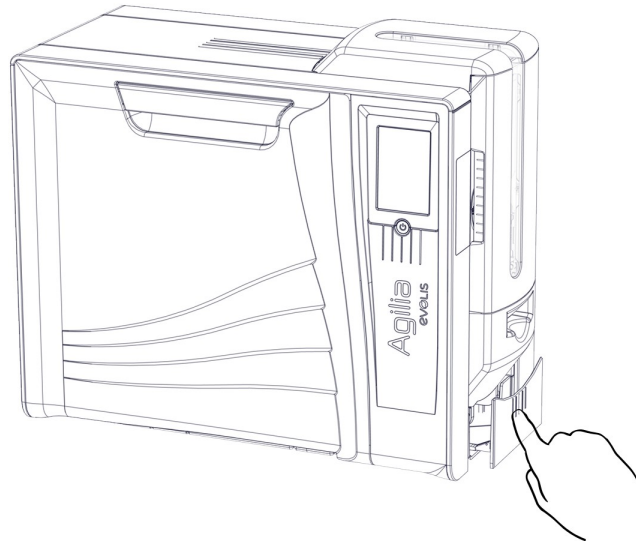

1. Press on the middle of the output box.

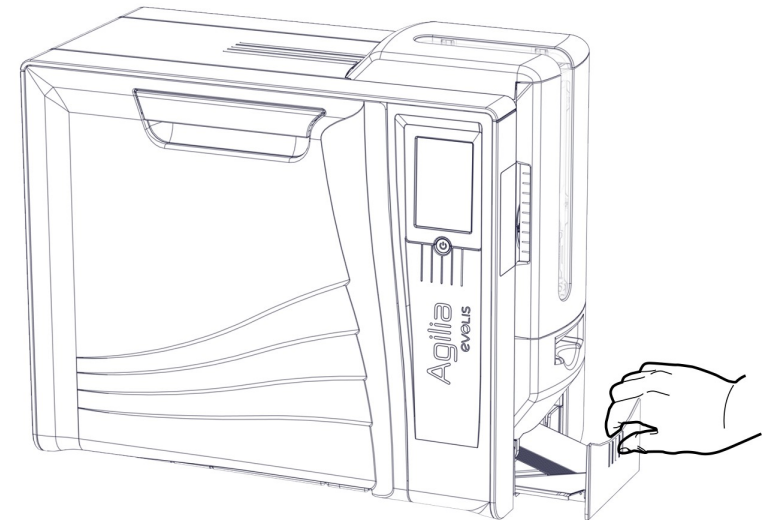

2. Pull the output box.
3. Remove the cards.
4. Close the front output box.

Cards are ejected by the bezel

Retrieve the ejected card from the bezel.



Installing Evolis Premium Suite 2

Evolis Premium Suite 2 is an all-in-one driver software solution that makes interactions between printer and computer more intuitive. Its advanced features automate printer configuration.

It includes

- A supervision of printers: printer status information, remaining ribbon capacity, etc.
- A powerful tool for printer settings
- A notification center to alert users when their intervention is required
- A printer management and maintenance station
- A series of wizards to guide you through cleaning and encoding operations, etc.
- An encoding station (magnetic encoding, etc.)
- A diagnostic tool

Installation procedure

- Make sure the printer is disconnected from the computer before installing Evolis Premium Suite 2.
 - It is possible to select Standard or Minimal installation: **Standard installation** is recommended as it includes notification and supervision features.
 - In case of a **network installation**, the printer driver must be installed in **Minimal installation**.
- 1 Download the Driver/Premium Suite file (.exe for Windows and .pkg for macOS) on www.evolis.com > **Support section** > **Product page**.
 - 2 Launch the installation program and follow the instructions.
 - 3 At the end of the installation, restart the computer, if requested.
 - 4 Connect the printer to the computer with the USB cable.

Installing cardPresso

- For information on how to use cardPresso card designer, see [cardPresso Help Center](#).
- 1 Go to www.cardpresso.com > **Downloads** to download cardPresso.
 - 2 Launch the installation file (.exe for Windows and .dmg for macOS) and follow the installation wizard.
 - 3 At the end of the installation wizard, a pop-up window is prompted to register the licence key. Type the activation code provided with the printer and click **Activate**.
 - 4 Click **Continue** to finalize the installation.



Connecting to a network (Optional)

- Evolis printers fitted with a TCP/IP network interface have an embedded http server.
- The printer is, by default, configured in DHCP mode (Dynamic Host Configuration Protocol), which means that its IP address is supplied by the network.
- Changing the printer's basic settings without prior knowledge of the layout of the LAN in question or without genuine technical knowledge may result in a malfunction of the printer, and may even extend to more widespread failure of all or part of the LAN.
- Contact your System and Network Administrator before connecting to or changing the settings for your local area network.
- For further details, refer to the **Network Administrator Manual**.

Evolis printers can be fitted with a TCP/IP network connection. To connect the printer, use the wizard available from the Evolis icon in the taskbar.

The network administrator can configure the printer in order to comply with the constraints imposed by the corporate LAN:

- Printer connected in a subnet, in DHCP
- Printer connected in a subnet with fixed IP address, and WINS resolution
- Printer connected in a subnet with fixed IP address, and no WINS resolution

The printer may be identified on the network in two ways:

- By its Hostname (NETBIOS)
- By its IP address

The Network connection wizard automatically detects all the Evolis printers installed.

The following settings can be configured:

- Printer IP address
- Subnet mask
- Gateway
- WINS server



Print Settings and Printing

Managing Print Settings in Evolis Premium Suite 2

- Detailed information about the settings are available on [Evolis knowledge base](#).
- If additional help is needed, contact your Evolis reseller before making changes.

Access to the settings in Evolis Premium Suite 2:

1. Click on the Evolis icon in the taskbar and click **Open Evolis Premium Suite 2**.
2. Select the printer.
3. Go to **Printer settings** to modify the settings.

The home page of the application displays:

- All connected printers (on-line and off-line)
- Printer status
- Printing ribbon and retransfer film capacity
- The number of cards that can be inserted before the next cleaning cycle.

What can be managed

- Cards input and output
- Resolution and printing speed
- Application of a color profile
- Colors settings (brightness, contrast, black printing)
- Overlay application
- Activation of security options (kineclipse and digital erasing)
- Standby and Hibernation modes
- etc.

Other actions

- Launching a cleaning cycle
- Updating the firmware and printer driver
- Printing test cards
- etc.



Starting with cardPresso

Evolis printers can be used from different applications with a print feature to print content. Set the document size to CR80 (85.6x53.98mm with 1mm margin) when required and select the printer name before launching a print job.

cardPresso software version XXS is supplied with the printer.

- For more information about the use of cardPresso, see cardPresso Help Center or click **Help** in cardPresso.
- If any issue occurs, see the [Evolis Knowledge Base](#) or [cardPresso Help Center](#).

- 1 Open cardPresso.
- 2 Click the **Create a new card** icon
- 3 Select the CR80 format.
- 4 The card design window is displayed. Customize the card by adding items (logo, illustration, identification photo, fixed and variable texts, barcode, etc.).
- 5 Click **File > Print**, select the printer and click **Print**.



Interacting with the printer

LCD Touchscreen

- For more information, see the LCD Touchscreen user guide available on www.evolis.com > **Support section** > **Product page**.

Permanent Status of Consumables and Cleaning



Lamination film



Ribbon and retransfer



Cards



Cleaning



Wi-Fi

Color status

The ribbon, cards, and cleaning statuses are always displayed in different colors to indicate the printer status:

- **Green:** Ready/OK for printing
- **Orange:** Alert/Warning
- **Red:** Error - cannot launch or continue print jobs
- **Dark gray:** Option is not present or detected by the printer.

The meaning of the color codes for the Wi-Fi option is different:

- **Wi-Fi icon green:** Option is present and activated but the printer is not necessarily correctly connected to the network.
- **Wi-Fi icon orange:** Option is present but not activated.

Displayed on the home page of the LCD Touchscreen:

- Printer activity
- Warnings and Error messages

When warnings are displayed with a QR code. Scan the QR code with a smartphone to access explanations and solutions to the issue.

If the Evolis Premium Suite 2 is installed in Supervised or Standard mode, there are two possible actions depending on the messages:

- Retry the print job



- Cancel the print job





Evolis Premium Suite 2 Notifier

- Notifications are displayed when the printer driver is installed in standard mode.
- Interrupting the notifier is only recommended when there is a conflict with other applications installed on the computer. The notifier is the best way to monitor the printer from a workstation.

Types of notifications:

- Messages about the maintenance of the printer.
- Messages and alerts associated with the ribbons, their compatibility with your printer or the nature of your print requests.
- Warnings about problems that have stopped the printer.

Color of the Evolis icon and printer status

When Evolis Premium Suite 2 is active, a small icon is displayed in the taskbar of the computer. The color of the icon varies according to the status of the printer:

- **Green:** Printer ready
- **Orange:** Warning message issued – printing may be stopped
- **Red:** Error message issued – printing stopped
- **Grey:** Printer in hibernation mode, disconnected or communication is interrupted.

Notifications can be disabled in Evolis Premium Suite 2. Click on the **User Preferences** icon  and deactivate the **Enable notifications button**.



4. OPTIONS

The following options are compatible with Agilia:

- Dual-side printing activation key
- Encoding options
 - Magnetic encoder
 - Contact encoder
 - Contactless encoder
- Kineclipse **(available in 2024)**
- Electromechanical locking system **(available in 2024)**
- Card Lamination Module **(available in the first quarter of 2024)**
- Wi-Fi **(available in 2024)**
- Ethernet data encryption **(available in 2024)**

- The following options are only factory-mounted:
 - Electromechanical system
 - Kineclipse

Dual side printing activation key

- A wizard is available to activate dual side printing in **Evolis Premium Suite 2 > Assistance & Maintenance > Maintenance > Installable options.**

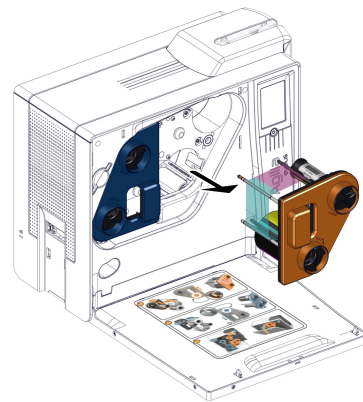

1. Open the door of the printer and remove the orange cassette.

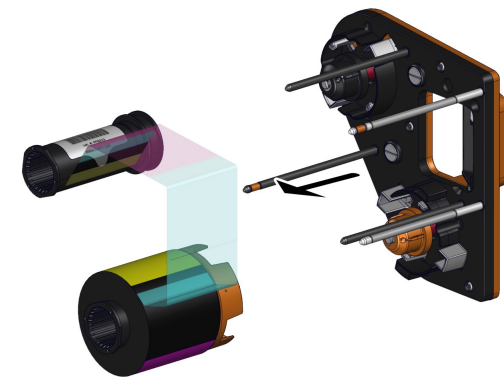

2. Remove the ribbon from the cassette. See [Remove the ribbon or retransfer film](#) ⁴³.

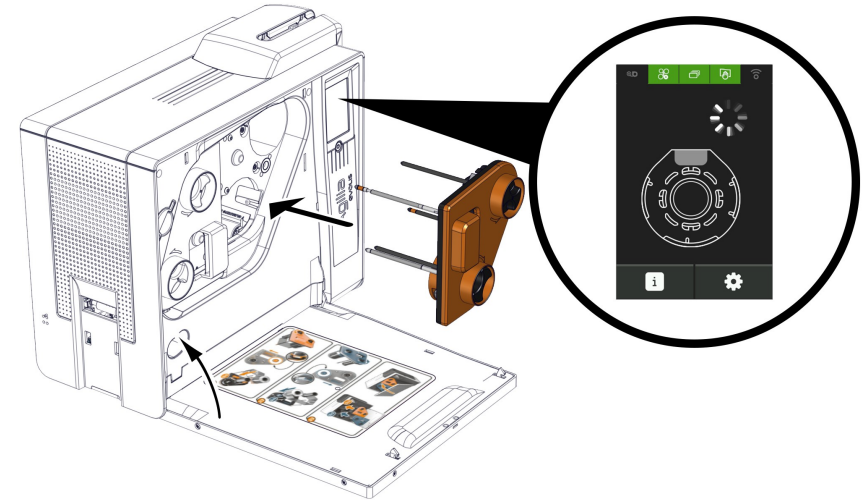

3. Install the activation key on the cassette. Make sure that the label of the key is facing the arrow.
4. Put the cassette in its compartment.
5. Close the door of the printer. The activation of the option starts.



6. When the activation process is complete, remove the activation key from the cassette and put the ribbon back in place. [See *Installing the printing ribbon and retransfer film*](#) [15].



Card Lamination Module (available in the first quarter of 2024)

Installing the infrared kit on the printer

To connect the Card Lamination Module to a printer, an infra-red kit must be installed on the printer.

To install the infra-red kit, refer to the installation procedure supplied with the Card Lamination Module.

Installing the Card Lamination Module

- Always plug the power supply of the Card Lamination Module before the power supply of the printer. If not, the Card Lamination Module is not detected in Evolis Premium Suite 2.

1. Install the printer on the **Printer side** of the installation platform.

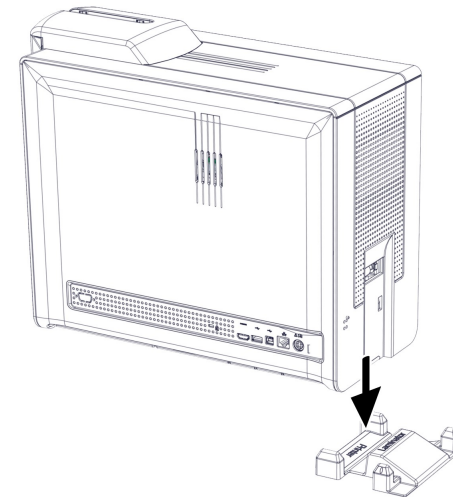



2. Connect the power supply and USB cable to the printer. See [Electrical connection](#) ¹³.

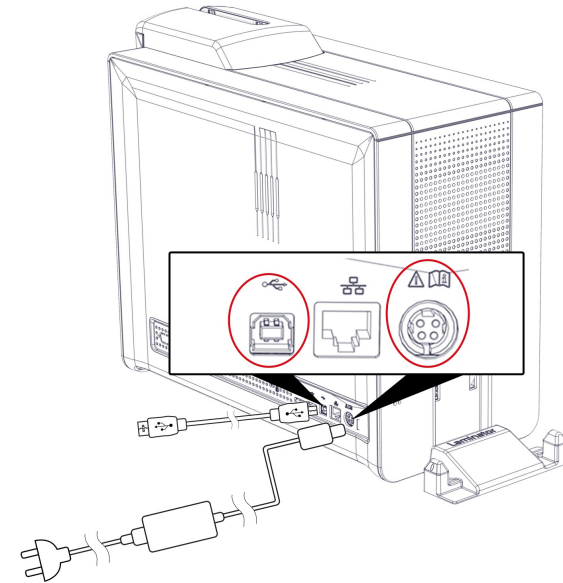

3. Connect the power supply to the Card Lamination Module .
4. Install the Card Lamination Module on the **Laminator side** of the installation platform. Make sure that both infrared connectors are facing each other and that the two modules are aligned.

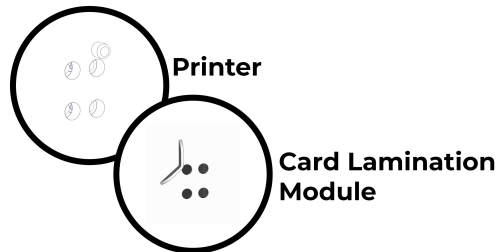

5. Plug the Card Lamination Module to an earthed wall socket.
6. Plug the printer to an earthed wall socket.

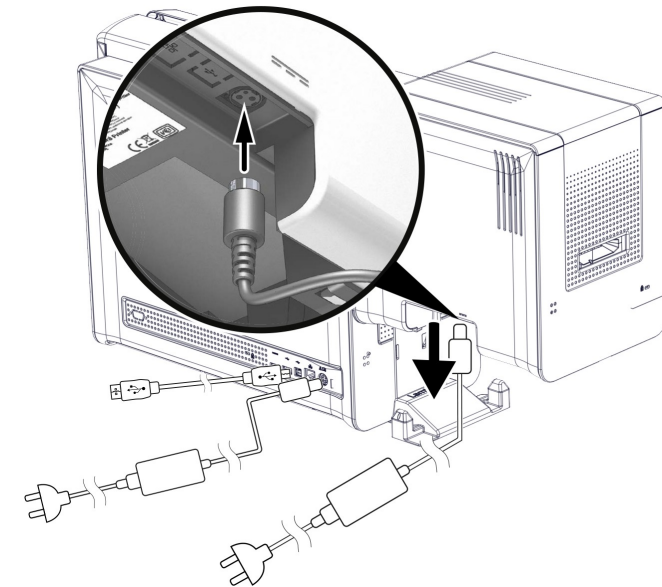



Installing the lamination film

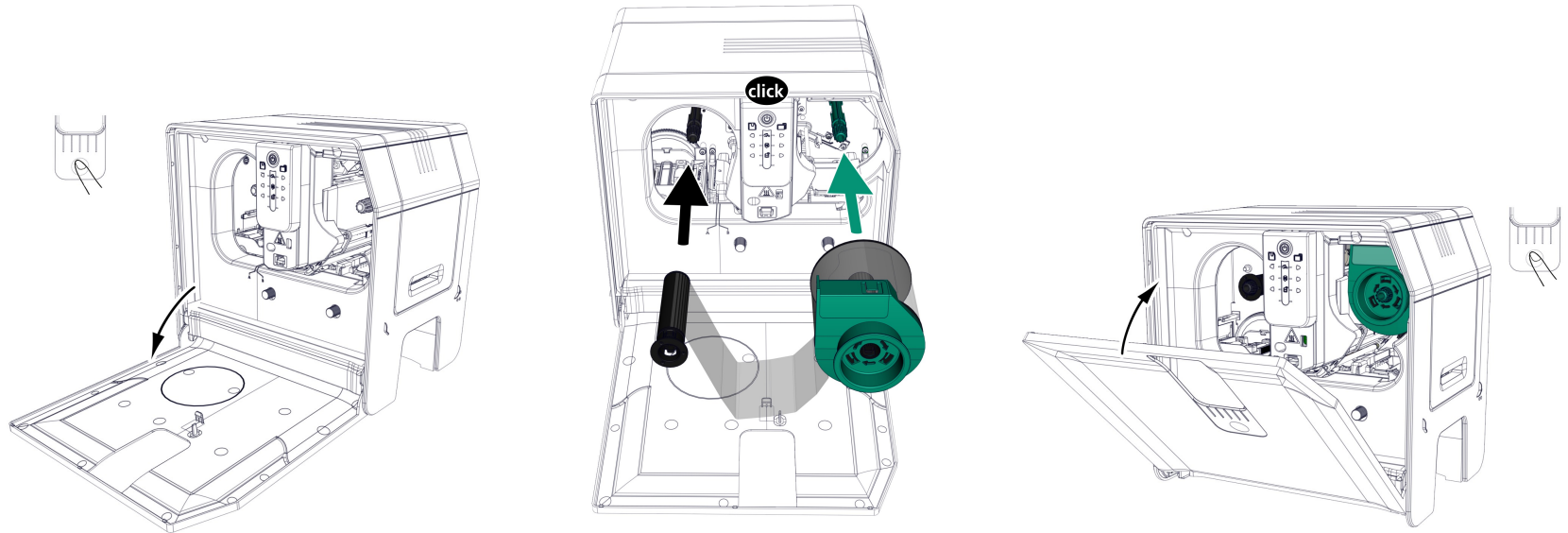

1. Push the door button to open the Card Lamination Module door.

2. Insert the lamination film until you hear a click on each roll. The flat side of the green roll must be facing up.

3. Close the Card Lamination Module door.







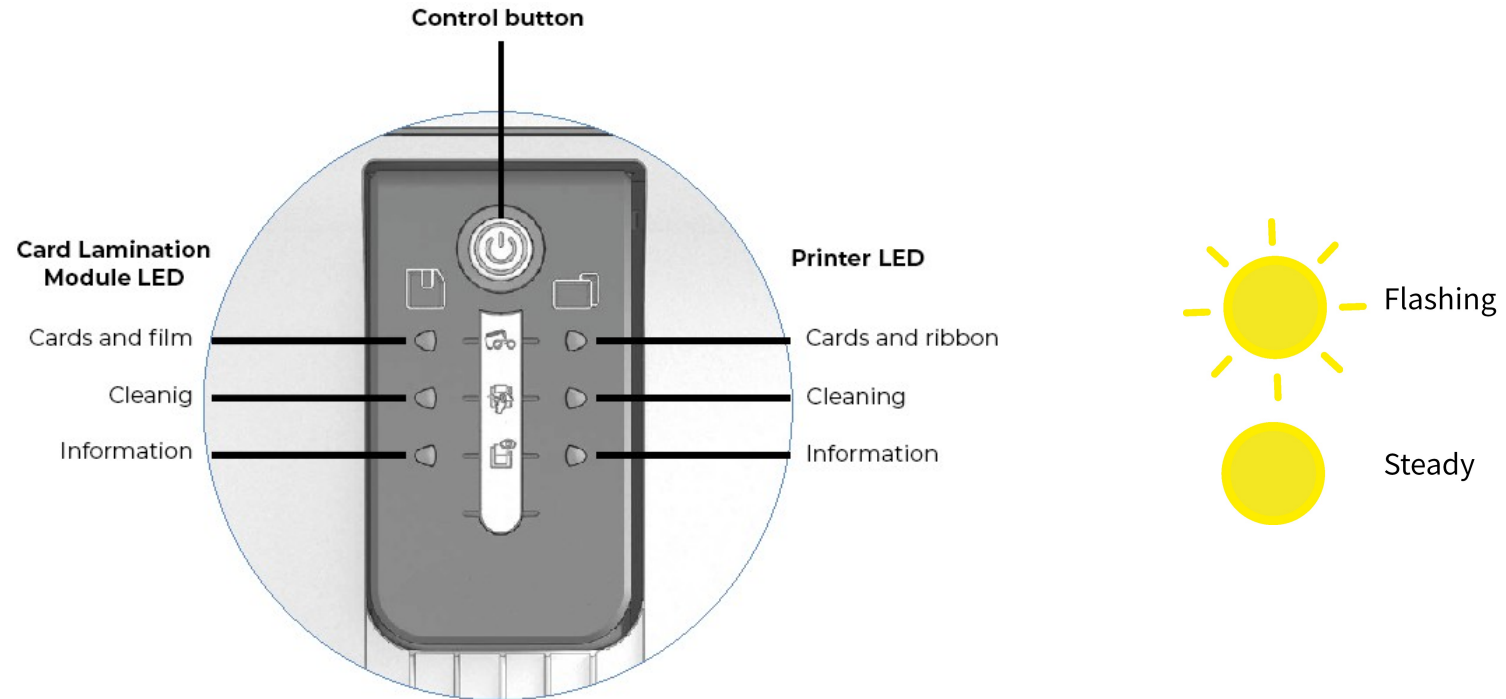



































Interacting with the Card Lamination Module

- The equipment may be equipped with an LCD screen instead of the control panel. Refer to the LCD touchscreen user guide for more information.





<p>PRINTER AND LAMINATION MODULE READY</p> <ul style="list-style-type: none"> The printer is ready to receive data. The lamination module is ready. 	<p>PROCESSING</p> <ul style="list-style-type: none"> The printer is receiving data. Lamination in process.
--	---



<div style="display: flex; justify-content: space-between; align-items: flex-start;"> <div style="display: flex; flex-direction: column; align-items: center;">      </div> <div style="display: flex; flex-direction: column; align-items: center;">      </div> </div> <p>PRINTING RIBBON AND RETRANSFER FILM</p> <ul style="list-style-type: none"> • No printing ribbon or retransfer film in the printer. • End of printing ribbon or retransfer film. • The printing ribbon or the retransfer film is not correctly fitted. • The printing ribbon or the retransfer film is torn. • The printing ribbon or the retransfer film is not recognized. <p>Check the condition of the printing ribbon and the retransfer film in the printer. If there is a print job in progress, it restarts with a new card.</p> <p>CARDS</p> <ul style="list-style-type: none"> • No cards in the card feeder. <p>Reload cards into the feeder – the process starts again.</p> <ul style="list-style-type: none"> • Error loading cards. <p>Check the cards are loaded. For any other problems, contact your Evolis reseller.</p>	<div style="display: flex; justify-content: space-between; align-items: flex-start;"> <div style="display: flex; flex-direction: column; align-items: center;">      </div> <div style="display: flex; flex-direction: column; align-items: center;">      </div> </div> <p>PRINTER DOOR OPEN</p> <ul style="list-style-type: none"> • The door of the printer is open. <p>Close the door again. The printer restarts.</p> <p>MECHANICAL ERROR</p> <ul style="list-style-type: none"> • Card jammed in the printer. • Mechanical component fault. <p>Open the door of the printer and hold down the control button to eject the jammed card.</p> <p>If the problem persists, contact your Evolis reseller for assistance.</p>
<div style="display: flex; justify-content: space-between; align-items: flex-start;"> <div style="display: flex; flex-direction: column; align-items: center;">      </div> <div style="display: flex; flex-direction: column; align-items: center;">      </div> </div> <p>LAMINATION FILM</p> <ul style="list-style-type: none"> • No film in the lamination module. • No more film. • The film is not correctly fitted. • The film is torn. • The film is not recognized. <p>Check the condition of the film in the printer.</p>	<div style="display: flex; justify-content: space-between; align-items: flex-start;"> <div style="display: flex; flex-direction: column; align-items: center;">      </div> <div style="display: flex; flex-direction: column; align-items: center;">      </div> </div> <p>LAMINATION MODULE DOOR OPEN</p> <ul style="list-style-type: none"> • The door of the lamination module is open. <p>Close the door. The lamination restarts.</p> <p>MECHANICAL ERROR</p> <ul style="list-style-type: none"> • Card jammed in the lamination module. • Mechanical component fault. <p>If the problem persists, contact your Evolis reseller for assistance.</p>

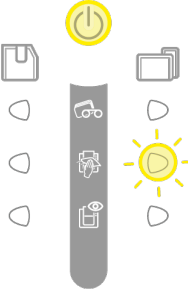

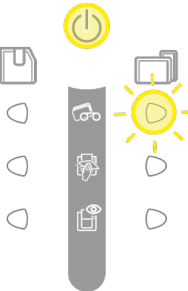
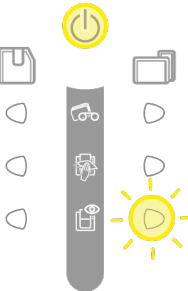
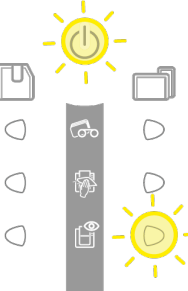
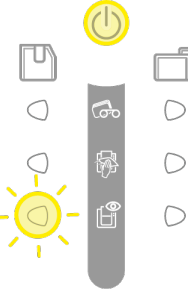
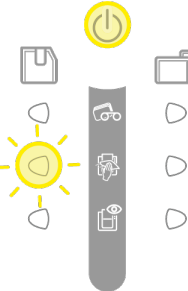
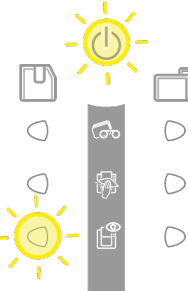
 <p>REGULAR CLEANING OF THE PRINTER REQUIRED (after 1,000 cards inserted)</p> <ul style="list-style-type: none"> The printer must be cleaned. <p>See Regular cleaning^[45]</p> <p>ADVANCED CLEANING OF THE PRINTER</p> <ul style="list-style-type: none"> The printer requires advanced cleaning. <p>See Advanced cleaning^[48]</p>	 <p>CLEANING OF THE PRINTER MANDATORY (after 1,200 cards inserted)</p> <ul style="list-style-type: none"> The printer must be cleaned to avoid the risk of the warranty being voided. <p>See Regular cleaning^[45]</p>
 <p>WAITING FOR CARD INSERTION OR REMOVAL</p> <ul style="list-style-type: none"> The printer is waiting for a card to be inserted or removed. <p>Insert a card or remove the card from the manual feeder.</p>	 <p>COOLING IN PROGRESS</p> <ul style="list-style-type: none"> The cooling system has been activated. <p>The printer pauses for a few seconds and restarts once it is back at its normal operating temperature.</p>
 <p>FIRMWARE UPDATE OF THE PRINTER IN PROGRESS</p> <ul style="list-style-type: none"> The printer is updating its firmware. <p>The printer is operational again after the update.</p>	 <p>CARD LAMINATION MODULE REGULATING TEMPERATURE</p> <ul style="list-style-type: none"> The lamination module heats up for a few seconds and is reactivated when the required temperature is reached.
 <p>ADVANCED CLEANING OF THE CARD LAMINATION MODULE REQUIRED</p> <ul style="list-style-type: none"> The lamination module requires advanced cleaning. <p>See Cleaning the Card Lamination Module^[51]</p>	 <p>FIRMWARE UPDATE OF THE CARD LAMINATION MODULE IN PROGRESS</p> <ul style="list-style-type: none"> The lamination module is updating its firmware. <p>The printer is operational again after the update.</p>



Using the levelers

The levelers correct any natural bending of the card caused by the lamination process. Cards can be more or less misshapen depending on the type of card and film used.

Two block support positions for the card (A and B) are available to ensure the cards are perfectly flat.

		PVC Cards	PET-F Cards	PC Cards
1 mil transparent patch	Single-sided	B	A	B
	Double-sided	B	B	B
1 mil holographic patch	Single-sided	A	A	B
	Double-sided	B	B	B
0.5 mil transparent patch	Single-sided	A	A	B
	Double-sided	A	A	B
0.6 mil holographic patch	Single-sided	A	A	B
	Double-sided	A	A	B
Varnish	Single-sided	A	A	B
	Double-sided	B	B	B
Holographic varnish	Single-sided	A	A	B
	Double-sided	B	B	B

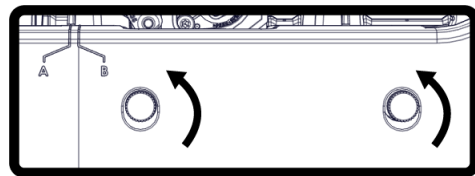

- 1 Open the door of the Card Lamination Module.
- 2 Loosen the two wheels as shown.

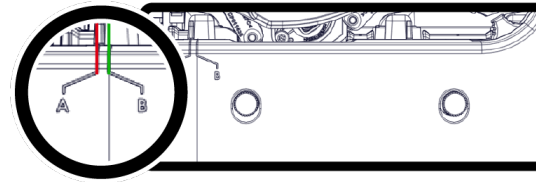

- 3 Depending on the type of card and film used, place the block support on position A or B (see the table).



- 4 Tighten the two wheels and close the door of the Card Lamination Module.



Encoding options

- The encoders (magnetic, contact and contactless) can be factory mounted or installed on-site by your Evolis reseller.
- Up to 3 encoding stations can be installed in the printer.
- Contact your Evolis reseller for more information about encoders or to have one or more encoders installed on a printer.
- **Smartcards** used for **magnetic encoding** must be inserted with the stipe facing down.
- **Smartcards** used for **contact encoding** must be inserted with the chip facing up.

Download the full technical specifications of the printer on www.evolis.com > **Product page** to know what types of encoders are compatible with your printer model.

Magnetic encoding

- Use only magnetic stripe cards that comply with ISO 7810 and ISO 7811 standards.
- The magnetic stripe must be molded into the card to work properly.
- Never use cards with a glued-on magnetic stripe.

When first installing the Evolis Premium Suite 2, the magnetic encoder functions need to be configured in **Printer settings > Encoding > Magnetic**.

Configure the coercivity (Hight or Low) in **Evolis Premium Suite 2 > Printer settings > Encoding > Magnetic**.

Factory setting is HiCo (Hight Coercivity).

Coercivity sets the magnetic encoding to high (HiCo) or low (LoCo) coercivity. A magnetic stripe that is encoded with high coercivity is more resistant to external disturbance than a magnetic stripe encoded using low coercivity.

Configure stripes to select the desired format for each stripe, according to the following table.

ISO 7811 magnetic encoding standards

Stripe number	Separator	Density (dpi) ¹	Character set ²	Number of characters ³
STRIPE 1	^	210	Alphanumeric (ASCII 32-95)	79
STRIPE 2	=	75	Numeric (ASCII 48-62)	40
STRIPE 3	=	210	Numeric (ASCII 48-62)	107

¹ Dots per inch

² Except for the "?" character

³ Including the Start, Stop and LRC characters. These characters are handled automatically by the magnetic encoder



Location of the magnetic encoder

The read-and-write head is located under the path taken by the cards and before the print head.

The encoding sequence for a card is always carried out before the printing.

The encoder encodes in a single pass and then runs a data check.

Encoding cards

Cards can be encoded from the printer driver, cardPresso or other applications.

Encoding from the printer driver

Select **Assistance & Maintenance > Tools and diagnostic > Support tools > Encoding** to directly encode one or more magnetic stripes.

1. Select each track and enter the data to be encoded according to the configuration of the stripes.
2. Click on **Encode track(s)** to run the encoding cycle.
3. Click on **Read track(s)** to make sure the data were correctly encoded.
4. Click on **Eject card** to eject the card.

Encoding via an application

Encoding via an application is used to encode magnetic stripe cards from applications such as Word for example.

A text field enclosed within “[” and “]” characters (or some other character which the user can define) will be interpreted as an encoding command by the printer driver.

More information about magnetic encoding is available on the [Evolis knowledge base](#).

Cleaning the magnetic encoder

Cleaning of the magnetic encoder is performed when the printer runs an advanced cleaning cycle.

The advanced cleaning cycle cleans the card feed rollers, the cleaning rollers, the print head and the magnetic encoder read-write head.

If, in between two regular printer cleaning runs, the read-write process fails with more than one card, it is recommended to run an advanced printer cleaning sequence manually.



Contact encoding

- Use only smartcards compliant with the **ISO 7816-2 standard**.
- Printing over the chip may cause permanent damage to the chip.
- Smartcards must be placed in the card feeder with the **contact chip facing up**.

This encoder is connected to the computer via a USB interface. **Encoding cannot be performed with an Ethernet connection.**

Location of the contact station

The contact station is located over the path taken by the cards and after the print head.

The encoding sequence for a chip is always carried out before the card is printed.

Card station interface

- For more information on encoding a smartcard or on the configuration of the card present signal, contact your Evolis reseller.
- A smartcard can be encoded with cardPresso software or [Evolis Premium SDK](#) and the SDK of the encoder.

Printers fitted only with a smartcard contact station (without integrated encoder) are fitted with a female DB-9 connector on the back of a printer.

This connector, directly connected to the contact station inside the printer, is also connected to an external coupler to encode the chip.

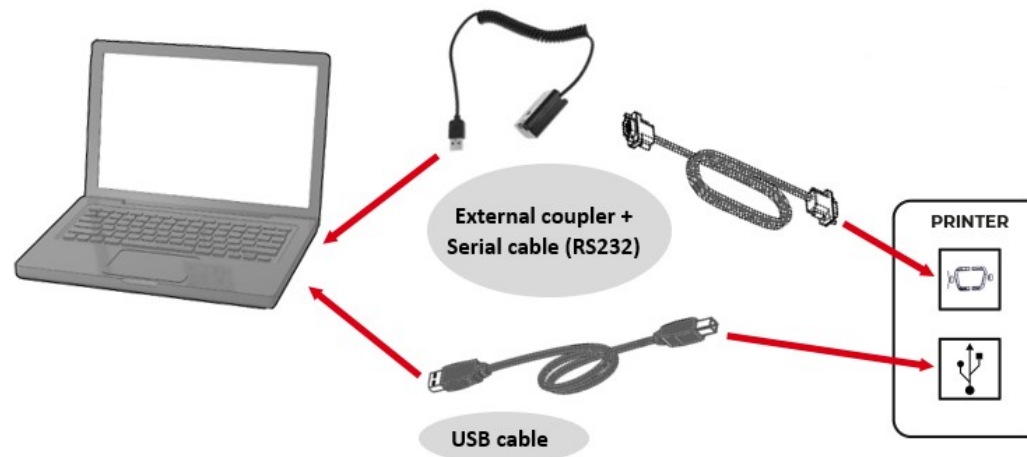



Contactless encoding

The Evolis product catalogue includes printers equipped with a built-in encoder for contactless chips.

This encoder is connected to the computer via a USB interface. **Encoding cannot be performed with an Ethernet connection.**

There is a very wide variety of contactless smartcards, and each card has specific technical properties associated with an equally specific type of encoder. Contact your Evolis reseller for further information.

Location of the antenna / encoder with built-in antenna

With a specific command, the card is positioned close to the antenna such that the card lies within its radio range.

Reading data from or writing data to the card can then start.

The encoding sequence for a chip is always carried out before the card is printed.

Card positioning

There are no restrictions on card positioning when encoding in contactless mode (except for cards comprising other encoding technologies: magnetic and/or contact smartcards).

If the cards used are fitted with mini-antennae, contact your card supplier for further information about where such mini-antennae are located within the card. Position the card as close as possible to the encoder's antenna to ensure optimum encoding.

Computer connection

- For more information on encoding a contactless smartcard, contact your Evolis reseller.
- A smartcard can be encoded with cardPresso software or [Evolis Premium SDK](#) and the SDK of the encoder.

If the encoder is supplied with an USB interface, it will either be connected to the printer's internal USB Hub, or equipped with a USB cable to connect to the computer directly.

In the first case, the printer's USB cable is used to drive firstly the printer and secondly the encoder from the computer.



Security options

Kensington lock

A Kensington lock is used to attach the printer with a Kensington cable.

Kensington cables are not provided or sold by Evolis. The user must acquire the cable by their own means.

The Kensington lock is located on the connectors side of the printer.



Electromechanical locking system (available in 2024)

- 2 keys are provided in the package.
- The printer can be unlocked with the key or using passwords. To know how to set and use the passwords, see the user guide of the LCD touchscreen available on www.evolis.com > **Support section** > **Product page**.

The electromechanical locking system is used to forbid the access to the following elements:

- Card feeder
- Cassettes
- Printer sides and internal mechanisms
- Reject box (front output box)



5. MAINTENANCE

Replacing a printing ribbon or retransfer film

- When manipulating the printing ribbon, the retransfer film and the cassettes:
 - Always put the cassettes on a flat surface with their pins facing up.
 - Do not grab the cassettes by the pins. It may result in the bending of the pins and printing quality issues.
 - Avoid dropping the cassettes. It may damage the pins and result in insertion difficulties or print quality issues.
 - Avoid touching the printing ribbon and retransfer film with your fingers.
- An installation procedure is available inside of the door of the printer.
- The cassettes are color coded to facilitate and prevent mistakes during installation. The blue cassette is for the retransfer film and the orange cassette is for the printing ribbon.
- Only use Evolis High Trust® consumables. These consumables bring you printing quality and reliability, maximizing the life span of the print head. The use of consumables other than Evolis High Trust® may lead to a bad printing quality and a dysfunction of the card printer.
- A tutorial is available on www.evolis.com > **Support section** > **Product page** to take ribbons apart and facilitate recycling.

Remove the printing ribbon or retransfer film

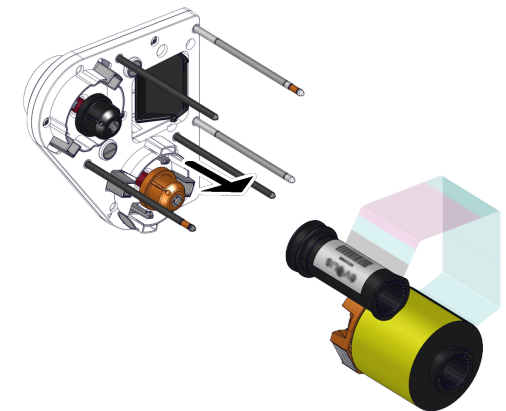
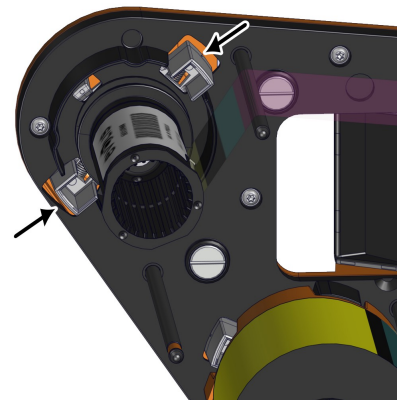
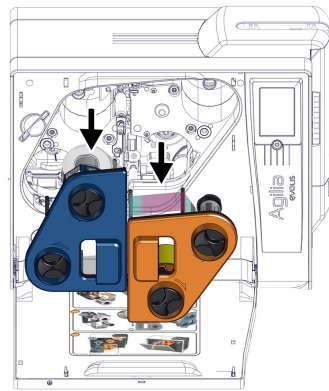

1. Open the door of the printer, pull the cassette out of its compartment.
2. Put the cassette on a flat surface with the pins facing up.
3. Press the 2 pressure buttons on the side of the ribbon or film rolls.
4. Pull the ribbon or film from the cassette.



Install the new printing ribbon or retransfer film

See [Installing the printing ribbon and retransfer film](#) ¹⁵.

Cleaning procedures

- Comply with the instructions given below to ensure a good functioning of the printer.
- The manufacturer's warranty is subject to a strict compliance with the routine servicing and maintenance instructions, and in particular the printer cleaning cycles.
- Any failure to follow the maintenance and servicing procedures described in this section voids the print head warranty.

Evolis declines any liability where there has been a failure to carry out required maintenance on the printer.

The print head is a wearing part and a sensitive printer component. Its useful life can be reduced by the presence of dust, liquids or solids in the printer's immediate environment, on the print head or on the cards. Users must take all necessary precautions to insert only clean cards, free of dust deposits or foreign bodies, into the machine.

The frequency and quality of cleaning are decisive factors enabling users to extend the print head's useful life and to ensure excellent print quality.

In addition, the use of Evolis High Trust® consumables ensures that the printer operates properly. Use of non-Evolis High Trust® consumables may affect the quality and reliability of print jobs, and even affect the printer's operation. The manufacturer's warranty does not cover physical damage or quality problems caused by the use of non-Evolis High Trust® ribbons.



Evolis provides replacement parts and consumables that you can refer to on www.evolis.com.



Regular cleaning

- The print head warranty is directly linked to the regular cleaning of the printer.
- Failure to perform this cleaning at the required times leads to the invalidity of the print head warranty.
- The printer is fitted with a cleaning warning system, which is triggered after a certain number of cards have been inserted. Proceed with the regular cleaning of the printer as soon as the warning is triggered. If you continue to run the printer despite the warning and if the warning light remains lit, the print head warranty is void because of failure to comply with contractual maintenance obligations.
- When cleaning the print head:
 - Avoid any contact between the print head and any metal or sharp objects. This could permanently damage the print head.
 - Avoid touching the print head directly with your fingers, as this could affect print quality or permanently damage the print head.
- Recommended cleaning cycle: Every time the retransfer film is changed. For more information, refer to the [Cleaning kit safety datasheet](#).
- Mandatory cleaning cycle: When the cleaning warning is triggered.
- **Servicing accessories: Adhesive cleaning card with 2 adhesive-free zones and cleaning swab impregnated with isopropyl alcohol.**
- When the cleaning cycle is over, wait 2 minutes before using the printer to let the alcohol evaporate.
- Cleaning cycles can also be launched from the Home page of Evolis Premium Suite 2 by clicking on the **Cleaning icon** .

► Video(s) of the procedure(s) available on www.evolis.com > Support section > Product page.

Printer	Cleaning required after: 	Number of cards remaining before warranty voided: 	Warranty invalid after 
Agilia	1000 cards	200 cards	1200 cards



Cleaning the cassettes

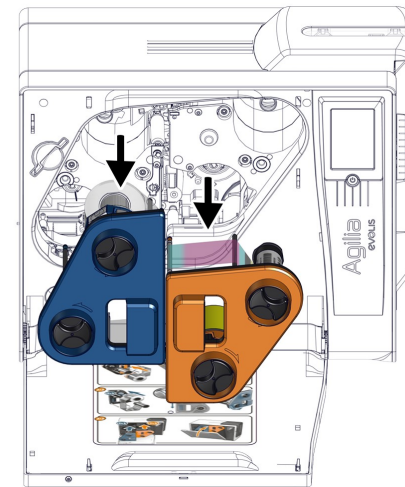
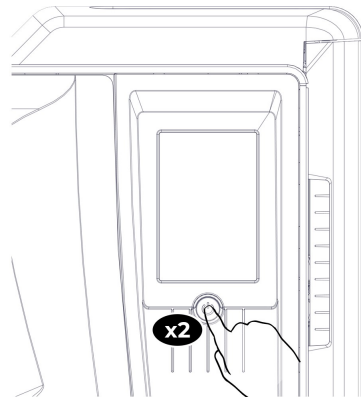

1. Press the push button twice. The cleaning wizard is displayed on the LCD touchscreen.
2. Open the card feeder and remove all cards present in it.
3. Set the card thickness selector on 50mil – 1.25mm.
4. Close the card feeder.
5. Open the door of the printer, remove the cassettes and put them on a flat surface with their pins facing up.
6. Remove the printing ribbon and retransfer film from the cassettes. (see [Replacing a printing ribbon or retransfer film](#) ^[43]).
7. Take a swab, press the middle so that the cotton is impregnated with alcohol.
8. Rub all the pins of each cassette.



Cleaning the print head

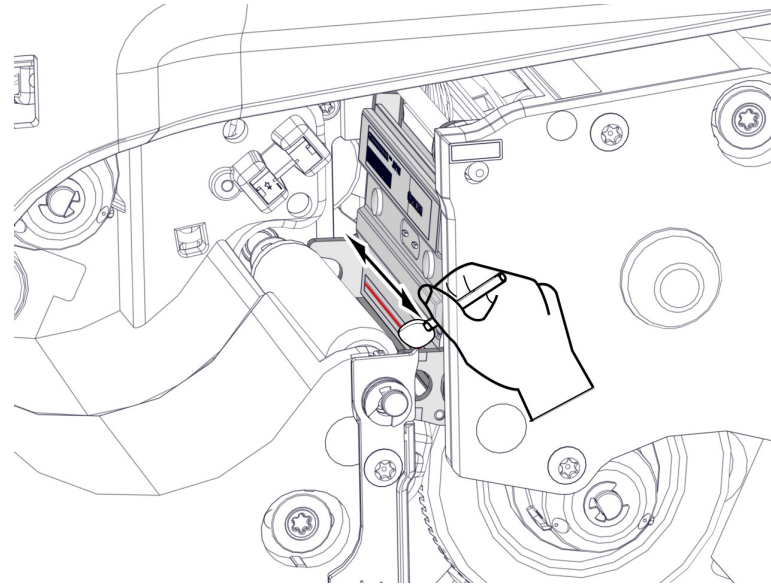

1. Locate the print head.
2. With the same swab, rub the black dotted line of the print head (In red here).

Cleaning the printer

1. Remove the film from the adhesive card and insert the adhesive card into the rear output slot (adhesive side up). The cleaning starts. When the cleaning is over, the used adhesive card is ejected into the output box.
2. Put the ribbon and film back on the cassettes and put the cassettes back in place. (see [Installing the printing ribbon and retransfer film](#)^[15]).
3. Put the cards back in the card feeder, reset the card thickness selector and close the card feeder.



Advanced cleaning

- When cleaning the print head:
 - Avoid any contact between the print head and any metal or sharp objects. This could permanently damage the print head.
 - Avoid touching the print head directly with your fingers, as this could affect print quality or permanently damage the print head.
 - Recommended cleaning cycle: Every 4800 cards.
 - **Servicing accessories: Adhesive cleaning card with 2 adhesive-free zones, impregnated T-card (use just after the bag is opened), and cleaning swab impregnated with isopropyl alcohol.**
 - When the cleaning cycle is over, wait 2 minutes before using the printer to let the alcohol evaporate.
 - Cleaning cycles can also be launched from the Evolis Premium Suite 2 by clicking on the **Cleaning icon**  on the Home page.
- ▶ Video(s) of the procedure(s) available on www.evolis.com > Support section > Product page.

Cleaning the cassettes

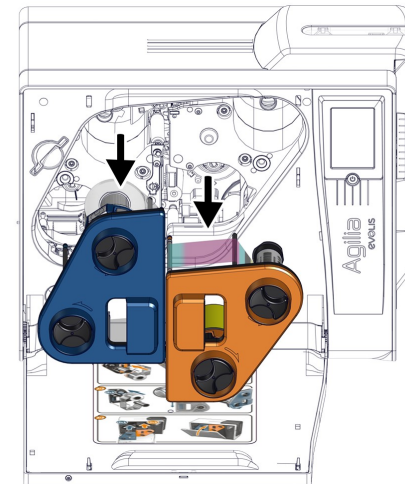
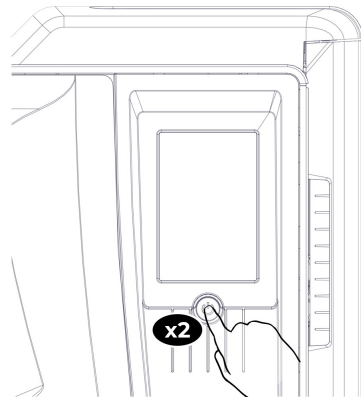

1. Press the push button twice. The cleaning wizard is displayed on the LCD touchscreen.
2. Open the card feeder and remove all cards present in it.
3. Set the card thickness selector on 50mil – 1.25mm.
4. Close the card feeder.
5. Open the door of the printer, remove the cassettes and put them on a flat surface with their pins facing up.
6. Remove the printing ribbon and retransfer film from the cassettes. (see [Replacing a printing ribbon or retransfer film](#) ^[43]).
7. Take a swab, press the middle so that the cotton is impregnated with alcohol.
8. Rub all the pins of each cassette.



Cleaning the print head

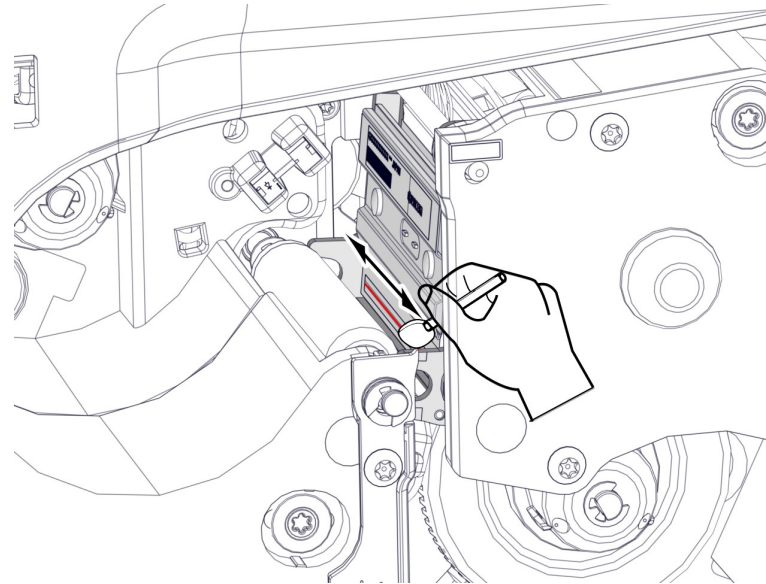

1. Locate the print head.
2. With the same swab, rub the black dotted line of the print head (In red here).

Cleaning the printer

1. Insert the T-card into the rear output slot. Cleaning starts.
2. When the printer ejects the T-card, remove it.
3. Remove the film from the adhesive card and insert the adhesive card into the rear output slot (adhesive side up). When the cleaning is over, the used adhesive card is ejected into the output box.
4. Put the ribbon and film back on the cassettes and put the cassettes back in place. (see [Installing the printing ribbon and retransfer film](#)^[15]).
5. Put the cards back in the card feeder, reset the card thickness selector and close the card feeder.



Specific cleaning

Cleaning the print head roller

- Recommended cleaning cycle: Every advanced cleaning cycle.
- **Servicing accessories: Cleaning swab impregnated with isopropyl alcohol.**

1. Open the door of the printer and remove the cassettes from their compartments.
2. Take a swab, press the middle so that the cotton is impregnated with alcohol.
3. With one hand, rotate the print head roller using the roll bearing (in red here).
4. While rotating the roll bearing, rub the swab on the print head roller (in black here).
5. Put the cassettes back in place and close the door of the printer.

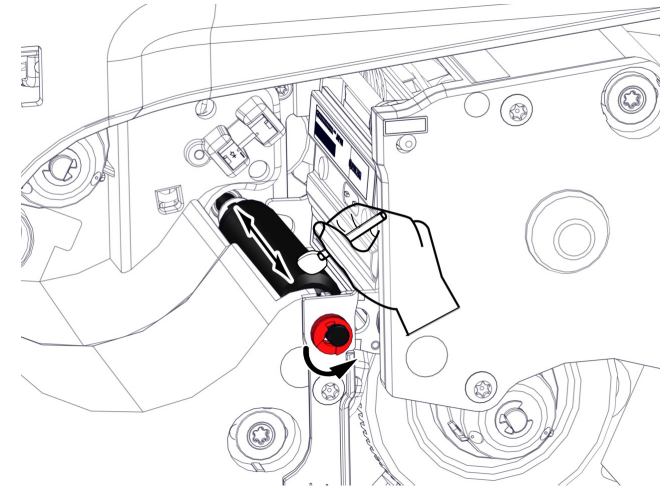

Cleaning the dust filter

- Recommended cleaning cycle: Once a year.
- **Servicing accessories: A gas duster.**
- The dust filter is located on the left of the retransfer cassette (blue).

1. Open the door of the printer.
2. Pull the dust filter out of its compartment. (See [Product Description](#) ⁹⁷)
3. Clear any dust from the filter with a gas duster.
4. Put the dust filter back in place.
5. Close the door of the printer.



Cleaning the Card Lamination Module

- Recommended cleaning cycle: Once a year or every 10,000 cards depending on the work environment.
- **Servicing accessories: special adhesive cleaning card and cleaning wipes.**
- Cleaning cycles can also be launched from the Evolis Premium Suite 2 by clicking on the **Cleaning icon** on the Home page.

▶ Video(s) of the procedure(s) available on www.evolis.com > **Support section** > **Product page.**

Card Lamination Module

- 1 Remove the lamination film.
- 2 Remove the protective films on both sides of the special adhesive card.
- 3 Press on the control button twice. The push button flashes.
- 4 When the ribbon and cards LED is flashing and the push button light is steady, insert the adhesive card into the opening above the output hopper at the rear side of the module. The printer icon flashes.
- 5 Once the cleaning cycle is complete, remove the used special adhesive cleaning card. Put the lamination film back. Close the door of the Card Lamination Module. The equipment is ready to operate again.

Dust filter

- Before cleaning the dust filter, unplug the Card Lamination Module and disconnect it from the printer.
- The dust filter is located below the Card Lamination Module.

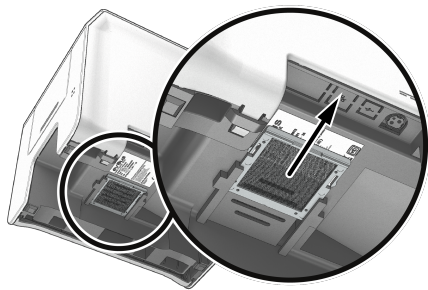

- 1 Remove the filter by pulling it and slide it out to release it fully.

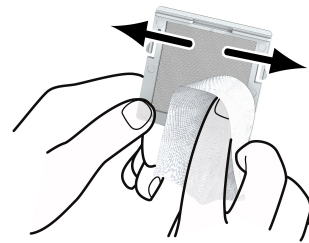

- 2 Take a cleaning wipe and clean the filter by rubbing the wipe over both sides.

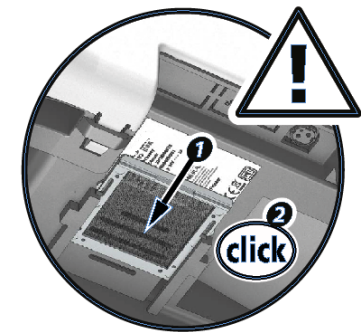

- 3 Put the filter back in place. Insert it in its slot (notch towards you) and push it until a click is heard.
- 4 Reconnect the Card Lamination Module to the printer and plug it back.



6. ASSISTANCE

Diagnostic Assistance

Printing a technical test card

- When receiving the printer, print a technical test card to make sure that the printer operates properly.
- When printing a technical test card:
 - Make sure there are at least one card, a printing ribbon and retransfer film in the printer.
 - Make sure the printer is ON.
 - Wait for all print jobs to be finished.

The following information is available on the technical test card:

- Printer model
- Serial numbers (Printer and print head),
- Firmware version,
- Cleaning operations,
- etc.

These information may be required by a reseller or technical support for assistance.

Print a technical test card from Evolis Premium Suite 2

1. Select the printer.
2. Go to **Printer settings**.
3. Click the **three-dot button** (top right corner of the interface) and select **Print a technical test card**.
4. Printing of the technical test card starts.

Print a technical test card from the LCD Touchscreen

1. Click the **Settings icon** , then **Printer test icon**  and finally the **Technical test card icon** .
2. Printing of the technical test card starts.



Printing a graphical test card

- The graphical test card can be printed from the Evolis Premium Suite 2 or the LCD Touchscreen.
- When printing a graphical test card:
 - Make sure there are at least one card, a color ribbon and retransfer film in the printer.
 - Make sure the printer is ON.
 - Wait for all print jobs to be finished.

The graphical test card is used to confirm the print quality, the absence of any potential offsets, and whether the ribbon is synchronized correctly.

Print a graphical test card from Evolis Premium Suite 2

1. Select the printer.
2. Go to **Printer settings**.
3. Click on the **3 dots menu** (top right corner of the interface) and select **Print a graphical test card**.

Print a graphical test card from the LCD Touchscreen

1. Click the **Settings icon** , then **Printer test icon**  and finally the **Graphical test card icon** .
2. Printing of the graphical test card starts.

Identifying installed software versions

In Evolis Premium Suite 2, go to **Assistance & Maintenance > Product information > Software versions**.

The following information can be found there:

- Installed version of Evolis Premium Suite 2
- Installed printer firmware
- Installed LCD firmware and graphics resources.



Troubleshooting

Printing Problems

- Most printing problems or printing quality problems are solved with an update of the printer driver and/or printer firmware. See [Updating the Printer Driver](#)^[57] and [Updating the Printer Firmware](#)^[57].

No Printing

- 1 Check the printer driver
 - Make sure that there is a printer driver for the printer in the Windows configuration.
 - Make sure the printer driver is up-to-date.
 - Make sure that the printer is selected as the default printer.
- 2 Check the printer's power supply
 - Make sure that the power cable is correctly connected to the printer and to a working electrical socket.
 - Make sure that the printer is ON and that the push button is lit.
 - Make sure the power supply unit supplied with the printer is being used.
- 3 Check the USB cable
 - Make sure that the USB cable connects the printer to the computer.
- 4 Check the ribbon and retransfer film
 - Make sure that the ribbon and retransfer film are correctly fitted on the cassettes and that the door is closed.
- 5 Check the cards
 - Make sure that there are cards in the card feeder.
 - Make sure that no cards are jammed in the printer.
- 6 Print a test card
 - See [Printing a Technical Test Card](#)^[52].

Blank Card Ejected

- printing ribbon or retransfer film
 - The printing ribbon or retransfer film may be finished. Replace the finished consumable. See [Replacing a printing ribbon or retransfer film](#)^[43].
 - The printing ribbon or retransfer film may be damaged. Repair the damaged consumable with transparent adhesive tape.
 - The printing ribbon or retransfer film may be incorrectly fitted. Install the incorrectly fitted consumable again. See [Installing the printing ribbon and retransfer film](#)^[15].
- The print head may be damaged
 - Print a test card.

If the test card is not printed, contact an Evolis reseller for technical support.



Poor Printing Quality

Small Blemishes on the Card



- The surface of the card may be dirty
 - Make sure that the cards are clean
 - Use new cards
- The cleaning rollers or the print head may be clogged
 - Launch a regular cleaning cycle

Horizontal Lines on the Card



- Ribbon and retransfer film
 - The ribbon and/or the retransfer film are not correctly fitted
 - Make sure there are no wrinkles on the surface of the ribbon
- The print head may be dirty or damaged
 - Clean or replace the print head

White card ejected



- The retransfer film is correctly applied on the card but nothing is printed on the retransfer film.
 - The printing ribbon may be incorrectly fitted
 - The printing ribbon may be finished. (See [Replacing a printing ribbon or retransfer film](#)⁴³).

Retransfer film not correctly applied

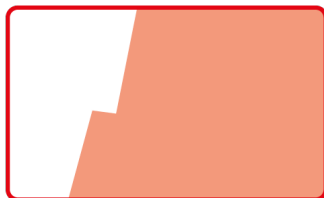

- Retransfer settings are not optimum.
 - Go to **Evolis Premium Suite 2 > Printer settings > Retransfer** to adjust the temperature and speed settings.
 - Make sure the temperature and speed settings correspond to the requirement of the selected card type.



Partial or Incorrect Printing

- We recommend buying cards from an Evolis reseller. Use of non-Evolis High Trust® cards may affect print quality and may damage the print head.
- Check the interface cable
 - If irregular characters are printed, make sure the USB cable supplied with the printer is being used.
 - Try using another cable of the same type.
- Launch a regular printer cleaning cycle
- Use clean cards.
 - Always keep the cards protected from dust.
- Make sure that the printing ribbon and retransfer film are fitted and move correctly.
- Check the print head
 - If horizontal straight lines appear on printed cards, the print head may be dirty or damaged.

See [Regular Cleaning](#) ⁴⁵.

If the problem persists, contact your Evolis reseller.

Jammed Cards

Freeing a Jammed Card

- Do not turn your printer off, as this cancels pending print jobs in the printer's memory.

The **mechanical error** signal is ON and printing is interrupted.

- 1 Open the door of the printer and remove the cassettes.
- 2 Press and hold the power button to activate the card feed rollers.
- 3 If the card is still stuck inside the printer, slide it manually towards the printer output. If there is more than one card, always push the top one first.
- 4 Put the cassettes back in place and close the door of the printer.

Preventing Jammed Cards

- Make sure that the card thickness selector is correctly adjusted.
- Make sure that the thickness of the cards used matches the technical specifications available on www.evolis.com > **Product page**.
- Make sure that the cards are flat. Keep them in an horizontal position.
- Make sure that the cards are not stuck together. Shuffle the cards before loading them.



Updating the Printer Firmware

- Update the printer firmware in these cases:
 - Printing or communication problems with the printer,
 - If you received a notification from the driver or your reseller advising you to update your driver
- Firmware updates are only required in case of an issue or malfunction.
- An update of the firmware that is not properly performed may result in a malfunctioning printer.
- In case of problems during the update of the firmware, contact your Evolis reseller who can provide a new installation file for the firmware.

The update of the firmware is performed from the printer driver or from the update notification.

- 1 Download the firmware file (.firm) on www.evolis.com > **Support section > Product page.**
- 2 Open Evolis Premium Suite 2 and click on the name of the printer. Go to **Assistance and Maintenance > Software version > Printer firmware version > Start the updates wizard.**
- 3 Follow the instructions and select the file .firm that was just downloaded.
- 4 The operation may take up to 1 minute. When the firmware is installed, the printer restarts. The update is complete and the printer is ready.

If the printer is not showing a **Ready** status, the update was not performed correctly or the printer is not working properly. Check the connection cables and run a new update.

Updating the Printer Driver

- Update the printer driver in these cases:
 - Printing or communication problems with the printer,
 - To benefit from new features available with new versions,
 - If you received a notification from the driver or your reseller advising you to update your driver.
- The printer driver can also be updated in **Evolis Premium Suite 2 > Assistance & Maintenance > Product information > Software versions.**

- 1 Download the Driver/Premium Suite file (.exe for Windows and .pkg for macOS) on www.evolis.com > **Support section > Product page.**
- 2 Double click on the file and follow the instructions of the installation program.



Technical Support

Evolis provides assistance to their users in case of difficulties using or configuring a printer.

Evolis Support section

Information on using and troubleshooting Evolis printers is available on www.evolis.com > **Support section**.

- Latest versions of firmware
- Latest versions of print drivers
- Latest versions of user manuals
- Videos on using and maintaining printers
- A knowledge Base

Evolis Partner Network

For unresolved technical problems, contact your Evolis reseller.

If you do not know any Evolis resellers, [contact us](#) to have the contact information of the nearest Evolis reseller.

When calling an Evolis reseller, make sure to be close to the computer connected to the printer and to provide the following information:

- Printer model and serial number
- The version of the operating system (computer)
- A description of the incident
- A description of what was performed to try and resolve the incident