

evolIS

Identify what matters

KC PRIME

USER GUIDE



Evolis © 2022. All rights reserved.

User-Guide_KSKC2_ENG_20220419_B0

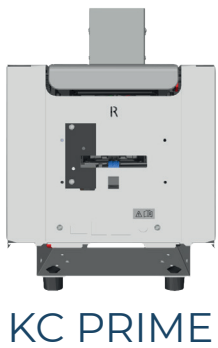
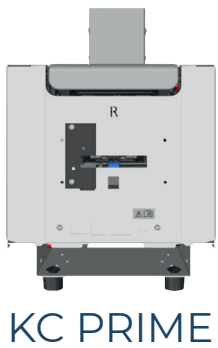

TABLE OF CONTENTS

Copyright	3
Trademarks	3
Warranty	3
Environmental Information	3
Recycling End-of-life Products	3
About Your New Printer	4
Icons	5
1. GETTING STARTED	6
Unpacking	6
Assembling the accessories	7
Printer Options	8
Printer Configurations	9
Printer Functions: external parts	10
Printer Functions: connection ports	11
Printer Functions: internal parts	12
Installation	13
Physical attachment in a kiosk terminal	13
Connecting the printer	14
Installing the driver	15
Ribbons	16
Cards	17
2. SERVICING	19
General Warranty Information	19
Printer Cleaning	20
Printer servicing	20
Servicing the Print Head	24
Maintenance of the dust filter	25
Application development	26
3. APPENDIX A	27
Declarations of Conformity KC Prime	27



COPYRIGHT

Evolis © 2022 All rights reserved.

Users must observe the copyright regulations applicable in their country. This manual must not be photocopied, translated, reproduced, or transmitted, in whole or in part, for any reason and by any electronic or mechanical means whatsoever without the express written consent of Evolis.

All the information contained in this document is subject to change without prior notice.

Evolis cannot be held liable for any errors that may be found in this manual, or for any loss or damage arising accidentally or as a result of dissemination or use of this manual.

TRADEMARKS

Evolis Premium Suite® and Evolis High Trust® are trademarks of Evolis. All other trademarks belong to their respective holders.

WARRANTY

Refer to the warranty notice for the terms and conditions and limitations. It is available on myplace.evolis.com

Register online at myplace.evolis.com to receive our special offers and general information.

ENVIRONMENTAL INFORMATION

Evolis is committed to helping the environment by reducing the energy consumption of its products.

RECYCLING END-OF-LIFE PRODUCTS

Manufacturing the equipment that you have purchased required the extraction and use of natural resources. This equipment may contain materials that are hazardous to health and the environment.

To prevent the dispersal of such materials into our environment and to reduce pressure on our natural resources, we recommend that you use existing collection facilities. These systems will re-use or recycle most of the materials in your end-of-life equipment in an appropriate way.

For further information on collection, re-use, or recycling systems, please contact your local or regional waste management organization.

Do not hesitate to contact us to find out more by visiting our website at myplace.evolis.com or by emailing the following address: info@evolis.com.

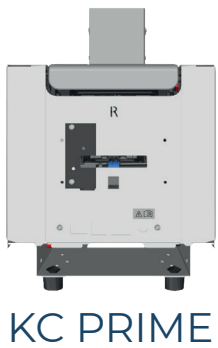

ABOUT YOUR NEW PRINTER

Using your new Evolis printer, you can create a wide variety of high-quality cards and personalized badges that can be printed and laminated in various thicknesses, colors, and styles. This printer uses consumables and accessories available from Evolis. For further details, visit our website at myplace.evolis.com.

Certifications and declarations of conformity:

- CE, UKCA, ICES, VCCI, BIS, CCC, KC, EAC, RoHS
- FCC (Evolis contact: Evolis, Rising Sun Mills, 188 Valley St., Suite 421, RI 02909 Providence, evolisnortham@evolis.com)

Icons on the printer label:



As evaluation for apparatus is only based on altitude not exceeding 2000m, it is the only operating condition applied for the equipment. There may be some potential safety hazard if the equipment is used at altitude above 2000m.



Evaluation for apparatus only based on temperate climate condition, therefore it's the only operating condition applied for the equipment. There may be some potential safety hazard if the equipment is used in tropical climate region.



The crossed-out dustbin symbol on your device is a reminder to use these facilities.

Dimensions:

- Printer (HxWxD): 307x196x 378 mm
- Feet height: 15 mm

Weight

- 5.3 kg

Connectivity

- USB (1.0, 1.1, 2.0, 3.0), Ethernet, Serial (option), Wi-Fi

Environnement

- Standard operating temperature: 15°C / 30 °C (59° / 86 °F)
- Humidity: 20% to 65% non-condensing
- Min / Max operating temperature and humidity rate: 0° / 40° C (32° / 104° F) and 20% to 65% non-condensing
- Min/max storage temperature: -5°C / +70 °C (23° / 158 °F)
- Storage humidity: 20% to 70% non-condensing
- Operating ventilation: free air

Electrical information

- Power supply unit: 100-240 Volts AC, 50-60 Hz, 1.7A
- Printer: 24 Volts DC, 2.71 A

To view all technical specifications, refer to www.evolis.com>Card Printers>Printer.

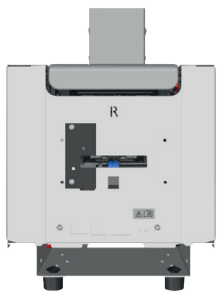

KC PRIME

ICONS

The following icons are used in this manual to highlight important information:



Information providing further details about certain points in the main text.



Indicates that failing to take the recommended action is likely to damage your printer.



A video showing the procedure is available on myplace.evolis.com.

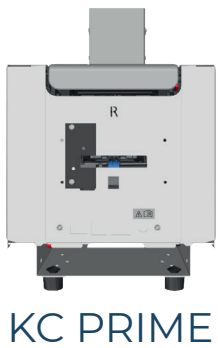

1. GETTING STARTED

UNPACKING

Your printer is supplied with several accessories that should be checked on receipt.

The list of accessories may vary depending on your location.

The printer is shipped in special packaging designed to prevent any damage in transit. If you notice any visible damage, please contact the shipping company and immediately inform your Evolis reseller, who will tell you the procedure to follow.

Evolis takes great care over the quality of its packaging and we ask that you keep this packaging somewhere clean and dry.



You will be asked for the full original packaging (outer box, inner wedges, and protective bags) in the event that the printer is returned. If the printer is returned without its original packaging and the components are damaged in transit, these components will no longer be covered by the warranty. A charge will be made for new packaging to reship the printer.

Accessories supplied with your printer:

- 1 power supply unit- CWT type KPL-065M-VI or FSP type FSP060-RAAK3
- Mains power cable
- USB cable
- Installation, documentation, and software CD-ROM
- Starter cleaning kit
- Feet kit
- 1 dust cover



If any of these components are missing, please contact your Evolis reseller.

Use only the power supply unit provided with your Evolis printer: CWT type KPL-065M-VI or FSP type FSP060-RAAK3.

Use only the USB cable supplied with your Evolis printer.



The Evolis printer must be placed in a dry location, protected from dust and drafts, but well-ventilated. Please ensure you keep your printer on a flat, solid surface able to bear its weight.



KC PRIME

ASSEMBLING THE ACCESSORIES

Depending on the use context, you may need to assemble the accessories provided with your printer.

Attaching the feet

To attach the feet, please refer to the instructions provided with the feet kit.

Attaching the dust cover

You may use the dust cover in the following cases:

- in dusty, smoky or humid environments
- inside and outside the terminal
- on a running or non-running printer
- in open or semi-open environments





KC PRIME

PRINTER OPTIONS

Options are described below. They may be already integrated in the printer or provided separately. In this case, their shipped kits contain all instructions of installation.



LED flashing bezel
(rear side)

By default, the bezel emits a flashing light signal when a card is inserted or a card is issued.

If the card issued is not taken by the end user, it remains in the bezel.

It is possible to change default setting through commands.

Anti-insertion optional feature prohibits the insertion of the card by a user but allows card issuance.



Encoding stations

Please refer to the driver User Guides for all settings linked to these options.

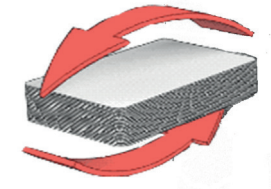

Duplex activation

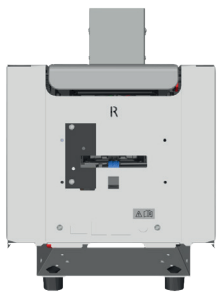

KC PRIME

PRINTER CONFIGURATIONS

Configuration #1

Front side



Without output hopper

Rear side

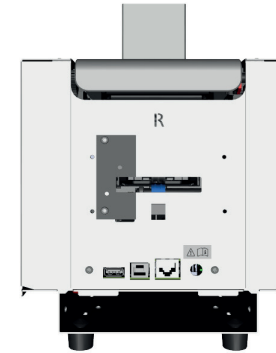

Without bezel
With connection ports

Configuration #2

Front side



With 200-cards feeder extension
With output hopper

Lateral side

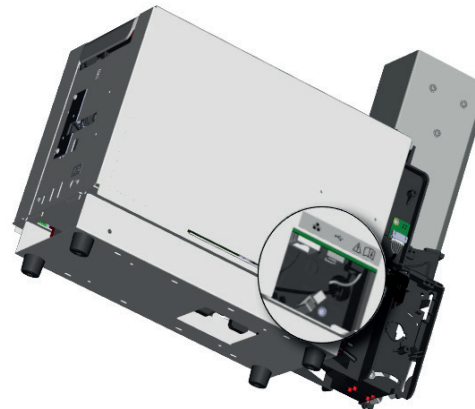

With connection ports

Rear side



With bezel
Without connection ports

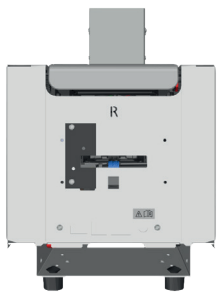

KC PRIME

PRINTER FUNCTIONS: EXTERNAL PARTS

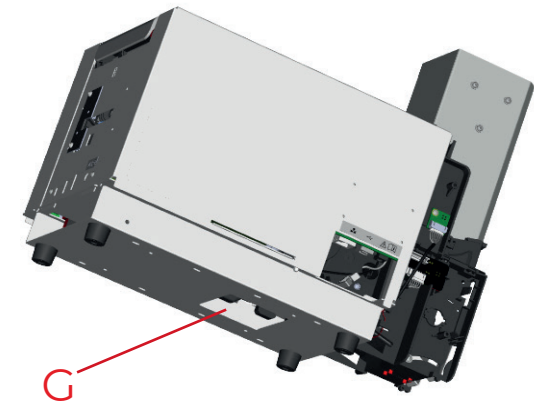
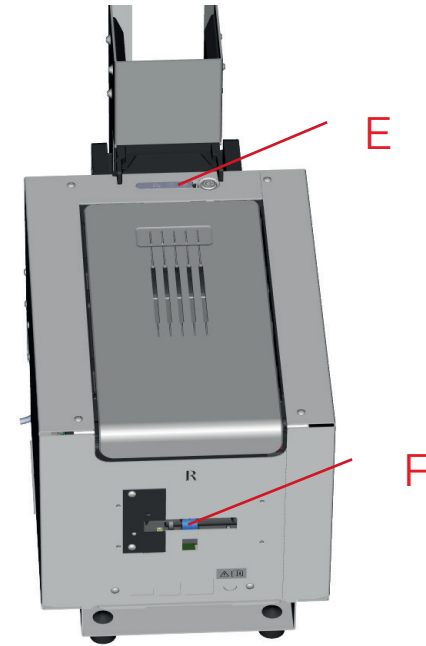
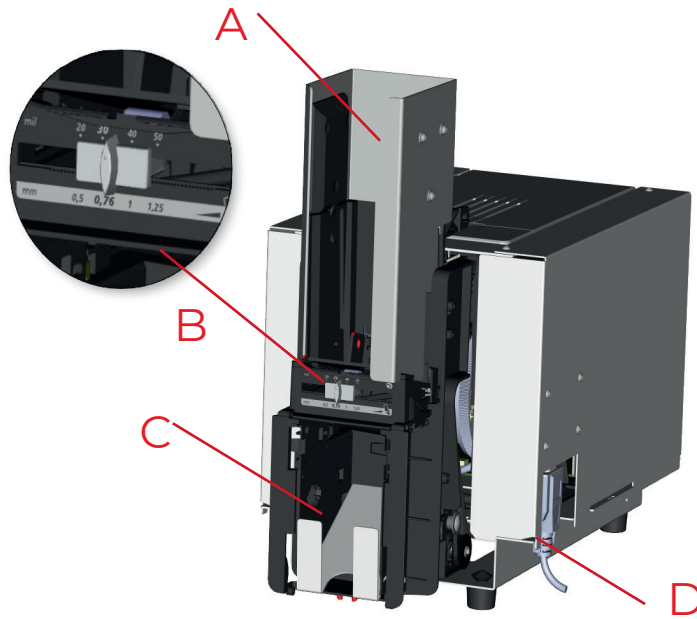

- A Card feeder
- B Card thickness adjustment gauge
- C Output hopper/Reject box
- D DB9 port to connect an external encoding station (optional)
- E Control panel
- F Rear input/output slot
- G Lower reject slot



PRINTER FUNCTIONS: CONNECTION PORTS

Configuration #1

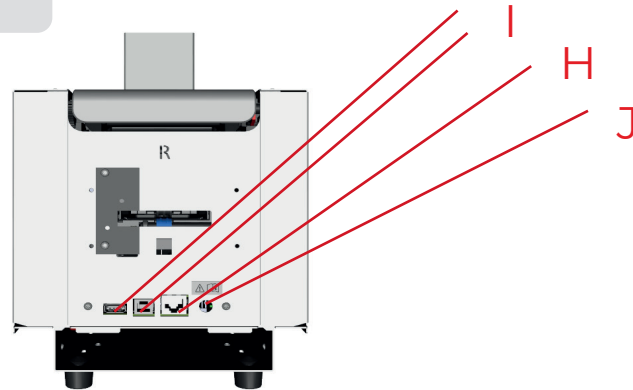

- H Ethernet port
- I USB ports
- J Power cable socket

Configuration #2

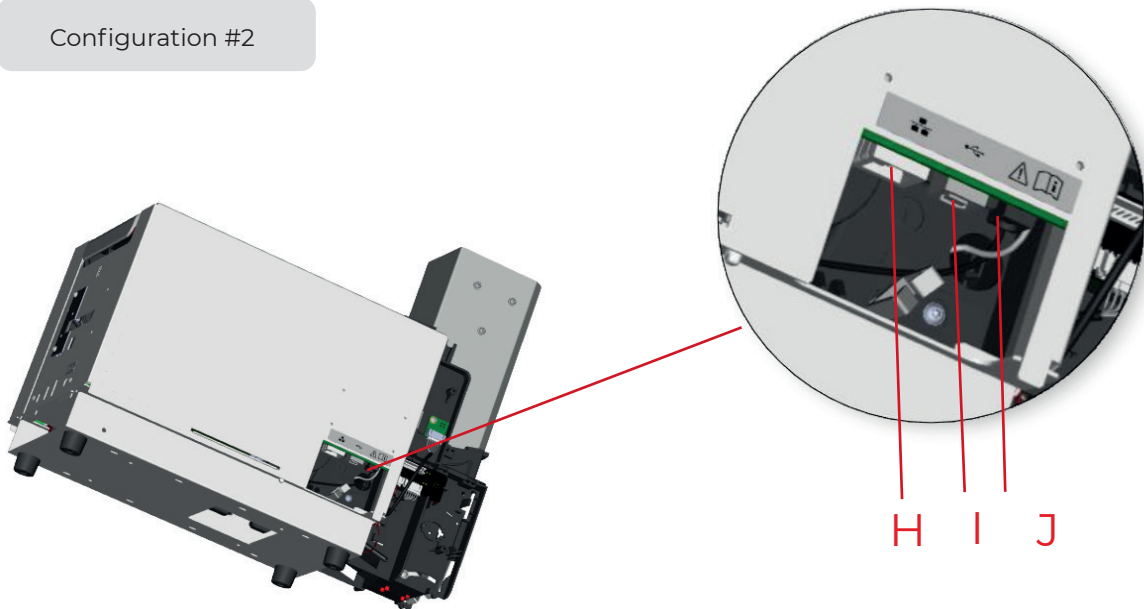

NOTE

If necessary and according to your on-premise installation, all connection ports are also available on the right side of the printer.

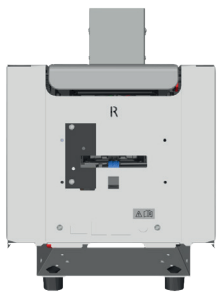

KC PRIME

PRINTER FUNCTIONS: INTERNAL PARTS

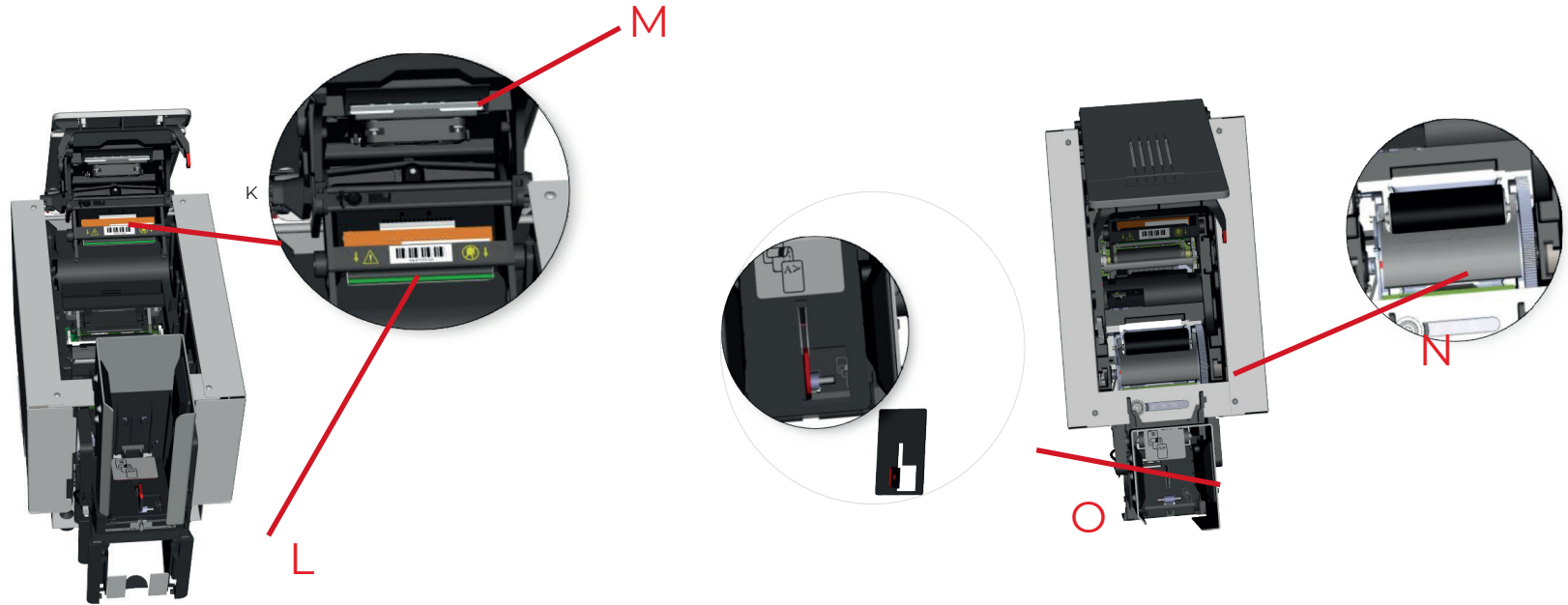

- K Thermal print head
- L Serial number label
- M Dust Filter
- N Cleaning roller
- O Feeder Weight

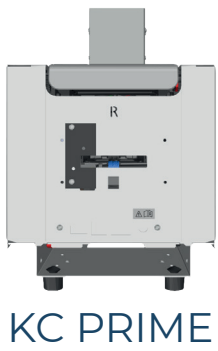

INSTALLATION

Physical attachment in a kiosk terminal

The KC Prime printers can be attached to the terminal using screws.

To do so:

- 1 If necessary, remove the 4 rivet feet from the bottom plate by pressing on their top.
- 2 There are 4 holes on the bottom plate to enable you to attach the printer to the terminal.

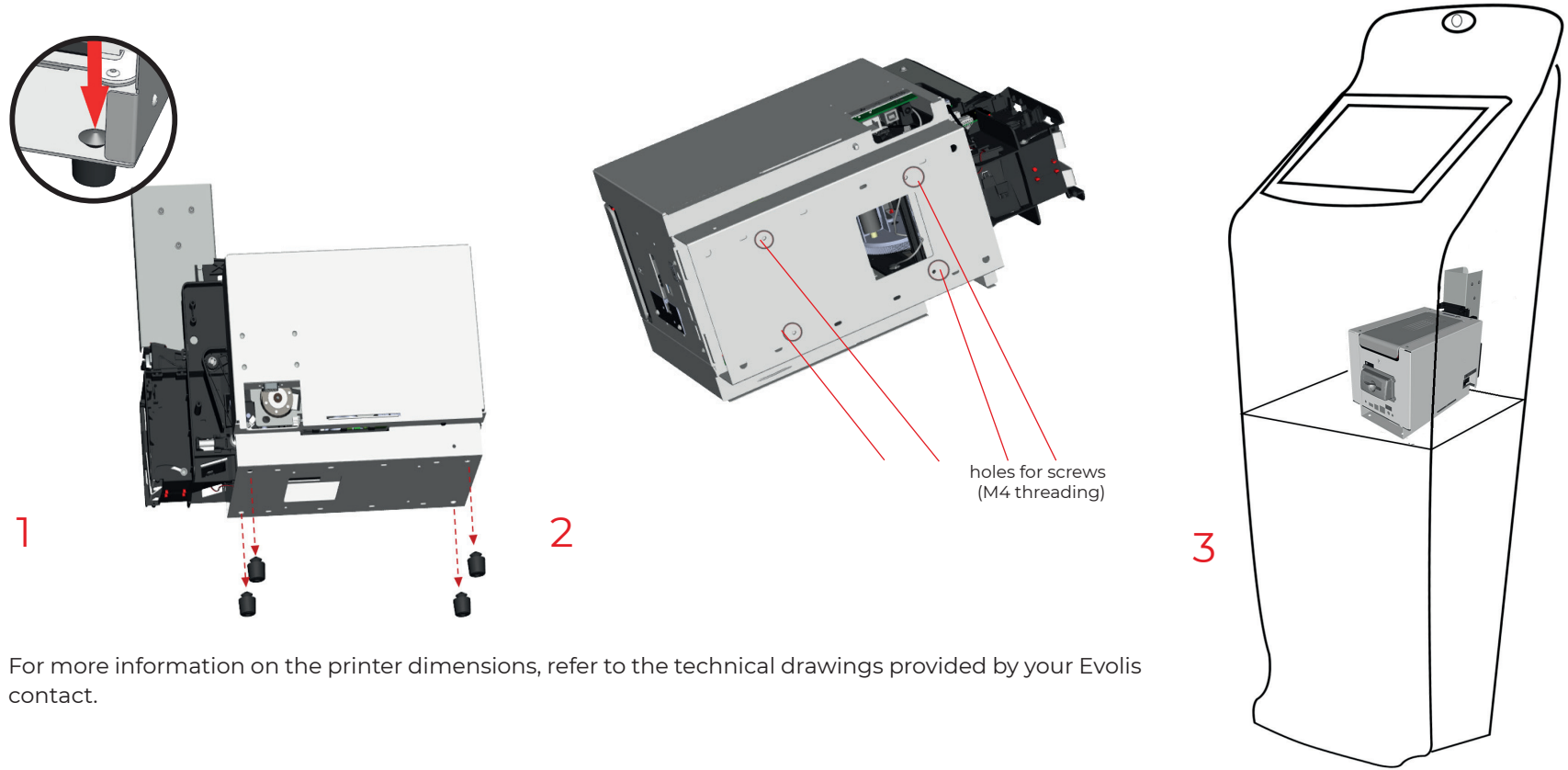

For more information on the printer dimensions, refer to the technical drawings provided by your Evolis contact.

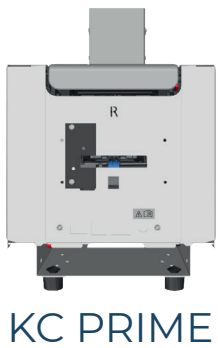

Connecting the printer



The printer must be connected to a properly protected and grounded electrical system.

FI: Laite on liitettävä suojamaadoitus koskettimilla varustettuun pistorasiaan.

NO: Apparatet må tilkoples jordet stikkontakt.

SE: Apparaten skall anslutas till jordat uttag.

DK: Printeren skal tilsluttes til en korrekt beskyttet og jordforbundet el-installtion.

To do so:

- Connect the power cable to the power supply unit, then plug the power cable jack into the printer



- Next, connect the power cable plug to a grounded power socket outside of the terminal.
- The printer is powered on: the control panel lights up indicating that the printer is working properly.

If the control panel does not light up, then either the installation has not been carried out correctly or the printer is not working properly. Check the installation.

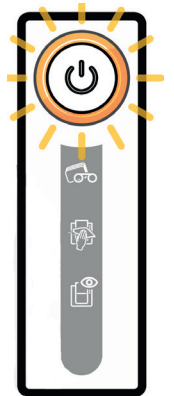

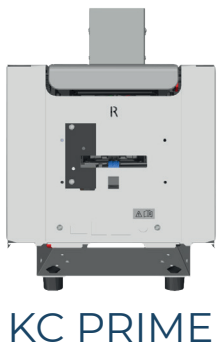

Installing the driver

Your printer is delivered with a CD-ROM comprising the Evolis Premium Suite®, which contains the print drivers for Windows and Mac OS platforms.

The Evolis Premium Suite® is an all-in-one driver software solution, which enhances the user experience by making the interactions between printer and computer more intuitive.

It includes:

- A print center that supervises the printers: printer status information, remaining ribbon capacity, etc.
- A powerful tool for printer settings
- A notification centre to alert users when their intervention is required
- A printer management and maintenance station
- A series of assistants to guide you through cleaning and encoding operations, etc.
- An encoding station (magnetic encoding, etc.)
- A diagnostic tool



Never plug-in the Evolis printer USB cable before launching the driver installation.
The installer will indicate when the USB cable can be plugged-in.



Follow the installation procedure scrupulously. All versions of Windows require the user to have administrator rights to install the driver.

To install the print driver:

On a Windows platform: insert the CD-ROM into your computer and select the print driver menu. A programme will guide you through the entire installation process.

On a Mac platform: insert the CD-ROM into your computer and double-click the .pkg format, which will start driver installation on your computer.



For all explanations and details on driver settings on Windows and Macintosh, please refer to the corresponding User Guides on myplace.evolis.com



KC PRIME

Ribbons

Evolis original High Trust® ribbons optimize the operation of your printer and avoid causing damage to it. The use of third-party ribbons may damage your printer and will void the manufacturer's warranty for the printer.

For optimum print quality, Evolis recommends that the printer is fully cleaned every time the ribbon is changed. See the Servicing chapter of this manual.

Fitting the ribbon



The printer automatically recognizes the ribbon inserted.

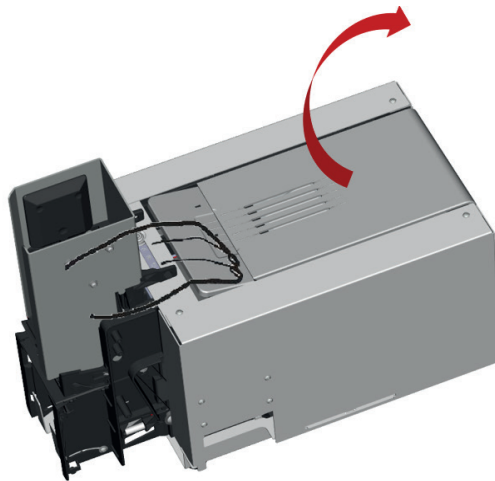

Open the cover.

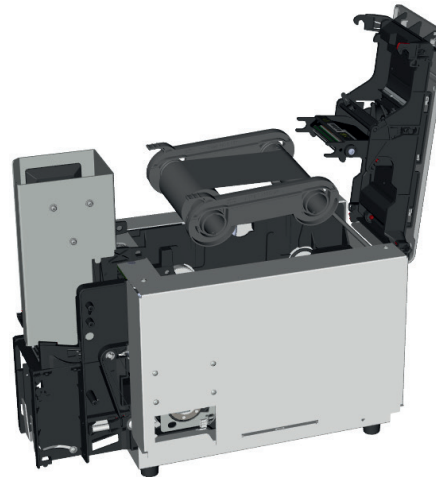

Insert the ribbon as shown.

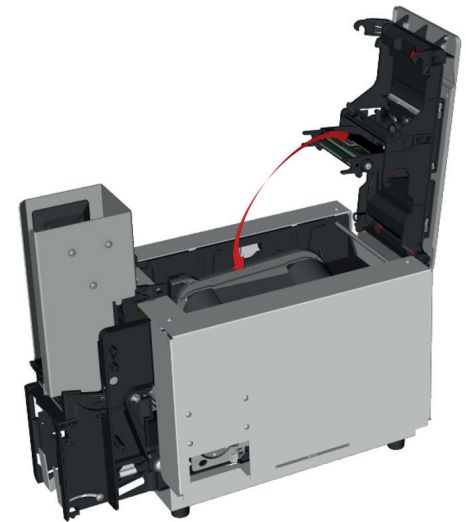

Close the cover and press until you hear a click.

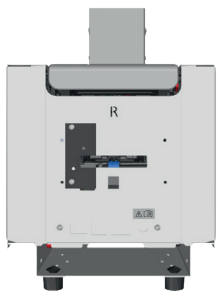

KC PRIME

Cards



For optimum quality, the cards used must be ISO 7810 certified.

Use only the card types recommended by Evolis.

Avoid touching the printable surface of the cards in order to preserve print quality.

Do not use cards that have been damaged, folded, embossed, or dropped on the floor.

Cards may be stuck together due to static electricity – avoid touching the card surface when separating them.

Storing new cards

Keep your cards protected from dust in their original packaging.

Loading the cards

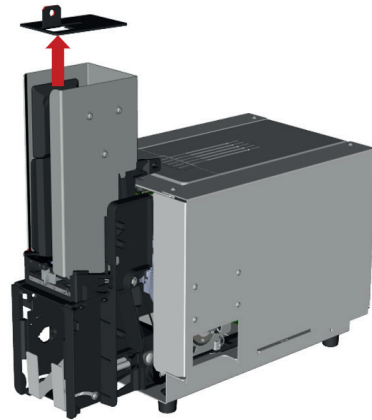

Remove the weight from the feeder.

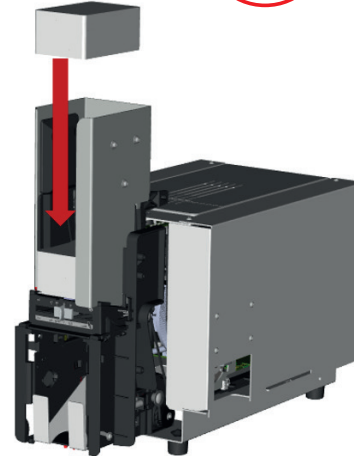

Insert the cards, 200 or 100 cards maximum (depending on the feeder capacity) with 0.76 mm thickness.

Hold and insert the cards as shown in the diagram.

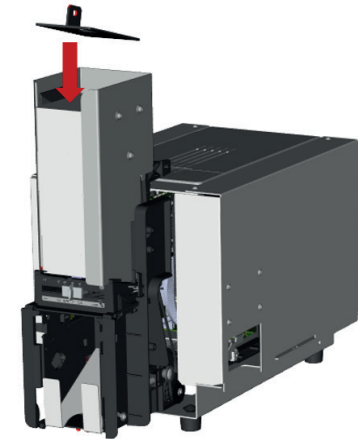

Put the weight back on the inserted cards.

You may select the Feeder side or the rear (R) side to insert the card, according to the way the printer is installed in the self-service terminal. To change the insertion setting, launch the EPS on Windows or CUPS driver on Macintosh and open the Feeder/Hopper tab.



KC PRIME

Removing printed cards

Once the print cycle is complete, the printed and/or encoded card is issued by default through the slot on the rear (R) side of the printer (with or without bezel).



To change the exit setting, launch the EPS driver on Windows or CUPS driver on Macintosh and open the Feeder/Hopper tab.



It is also possible to change the setting for the ejection of defective cards through the Feeder/Hopper tab.

Adjusting the card thickness

The printer is equipped with a manual card thickness adjustment system, which can be reached at the printer feeder.

The printer accepts cards between 0.51 mm and 1.25 mm thick (20 to 50 mil). The factory setting for card thickness is 0.76 mm.

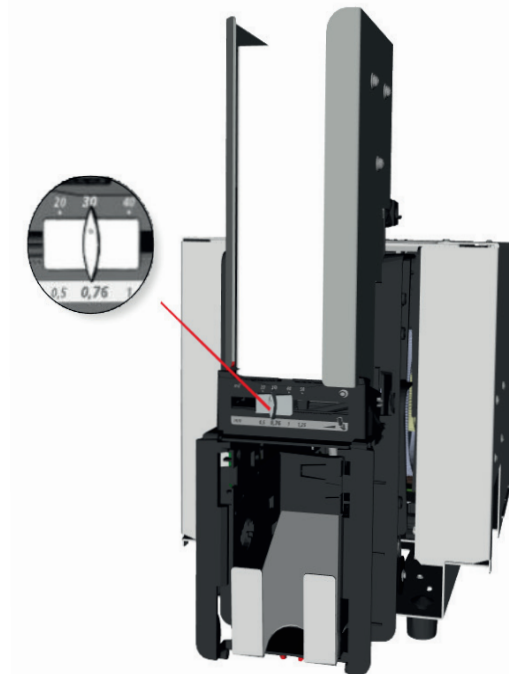

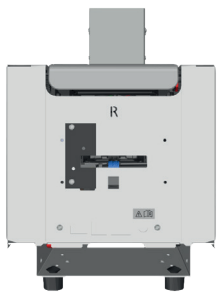

KC PRIME

2.SERVICING

GENERAL WARRANTY INFORMATION

Comply with the instructions given below to ensure that your printer runs satisfactorily.

Keep your warranty cover!



The manufacturer's warranty is subject to strict adherence to the routine servicing and maintenance instructions, and in particular the printer cleaning cycles.

Any failure to follow the servicing procedures described in this chapter will void the print head warranty.

Evolis declines any liability where there has been a failure to carry out required maintenance on the printer.

The print head is a wear part and an extremely sensitive component of the printer. Its useful life can be seriously curtailed by the presence of dust, liquids or solids in the printer's immediate environment, on the print head or on the cards. The user must take all necessary precautions to insert into the printer only clean, dust-free cards that are free of foreign bodies.

The frequency and quality of cleaning are decisive factors enabling users to extend the print head's useful life and to ensure excellent print quality. Particular care must therefore be taken with cleaning. The user must comply with the servicing and maintenance instructions given in this section.

In addition, the use of Evolis brand ribbons (Evolis High Trust®) also ensures that your equipment operates properly. The use of non-Evolis approved ribbons can therefore affect the quality and reliability of printing jobs, lead to poor quality printing, and even affect the operation of the printer. The manufacturer's warranty does not cover physical damage or quality problems caused by using non-Evolis approved ribbons.

Evolis supplies servicing items and consumables. You can find them on the website myplace.evolis.com.

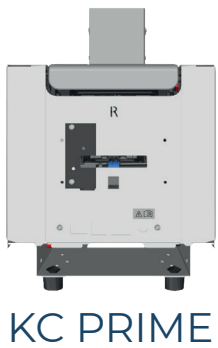

PRINTER CLEANING

Printer servicing



The print head warranty is directly linked to routine cleaning of your printer. If you do not carry out this cleaning at the required times, the print head warranty will cease to be valid.



Recommended cleaning cycle: whenever the ribbon is changed.
Mandatory cleaning cycle: when the cleaning warning is triggered.

Servicing accessory: pre-soaked T card and adhesive cleaning card.



Your printer is fitted with a cleaning warning system, which is triggered after a certain number of cards have been inserted. You should proceed with the routine cleaning of your printer as soon as the warning is triggered. If you continue to run the printer despite the warning and if the warning light remains lit, the print head warranty will be automatically voided because of failure to comply with contractual maintenance obligations.

In clean environments:

Printer cleaning required after: (warning light flashing)	Number of cards remaining before warranty voided: (warning light flashing)	Warranty invalid after: (warning light steady)
1000 cards	200 cards	1200 cards

In dusty environments, we strongly recommend to perform the cleaning after 500 cards.

Manual cleaning is also recommended every 5000 inserted cards and in case of card jamming. For more information, please refer to the Service Manual of the printer.

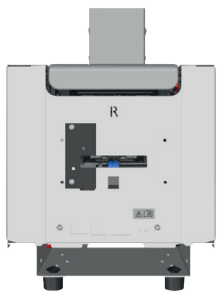

KC PRIME

Evolis provides an Evolis High Trust® maintenance kit consisting of 2 adhesive cards, 2 pre-soaked "T" shaped cards, a cleaning pen, and a box of wipes. The "T" shaped cleaning card is used to clean the transport rollers and the magnetic encoder head. Go through the following steps to validate cleaning.

Printer servicing



Servicing accessory: pre-soaked "T" shaped card and adhesive card.

Follow the procedure below:

- 1 Open the printer cover.
- 2 Remove the ribbon.
- 3 Close the cover and check it has clicked shut.

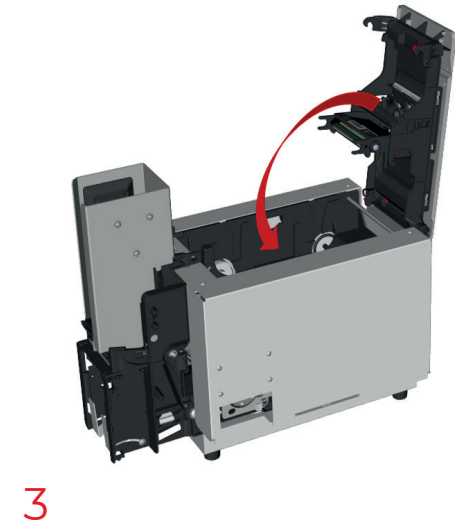
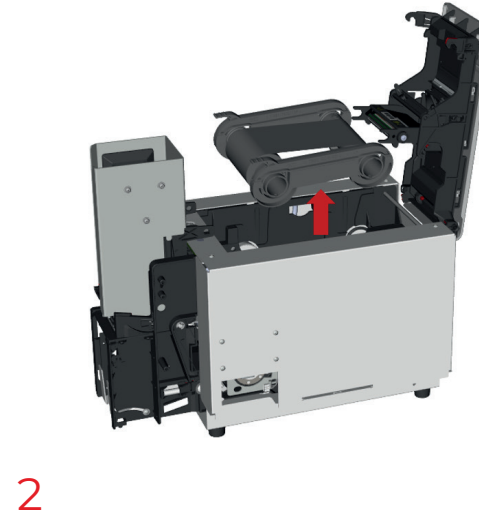
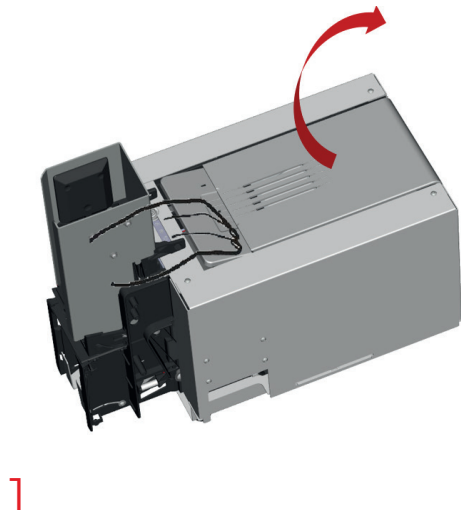



- 4 Using the gauge, set the card thickness to the MAX position.
- 5 Remove the cards from the feeder
- 6 Remove the 200-card feeder extension (if the printer is equipped with it).

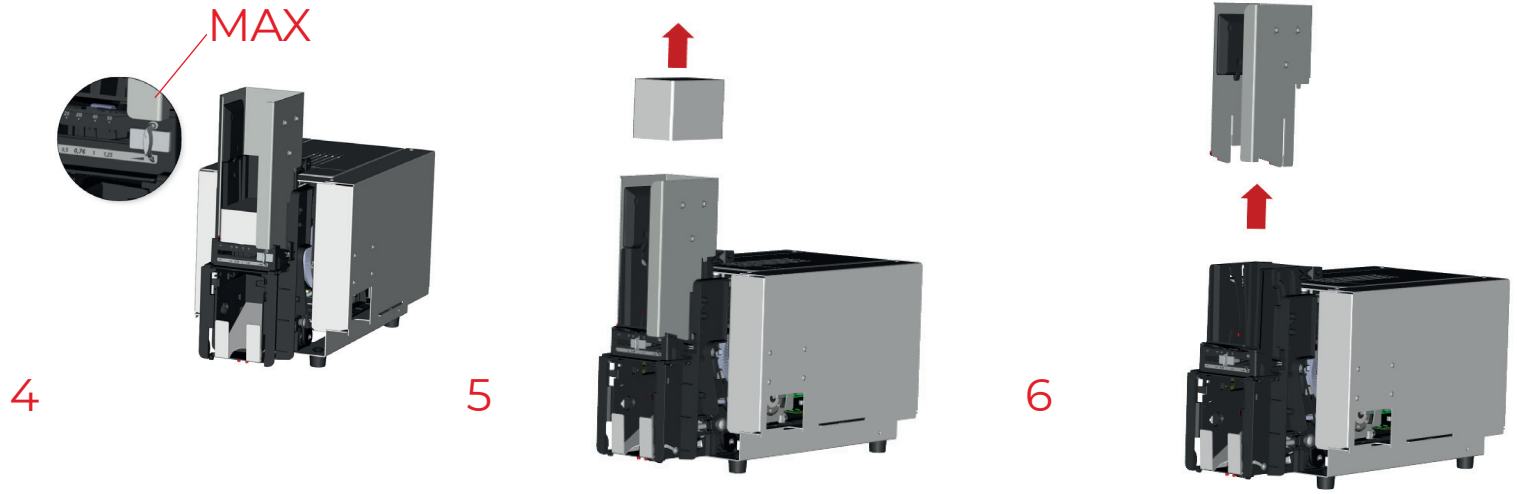

- 7 Double click the control button, then insert the "T" shaped card in the feeder as shown. Cleaning starts.
- 8 Once cleaning is finished, remove the "T" shaped card.

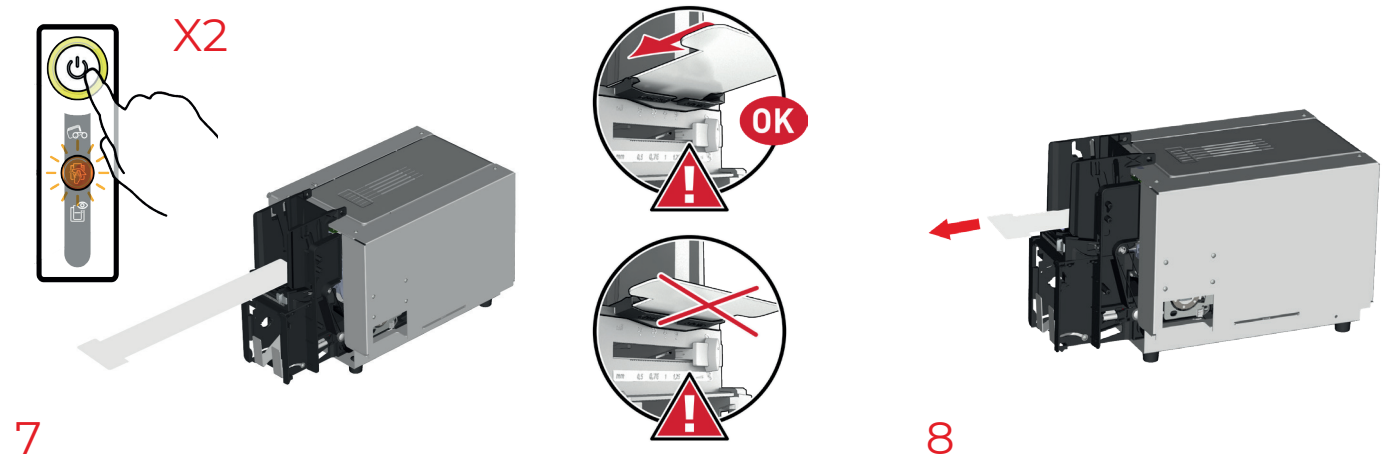

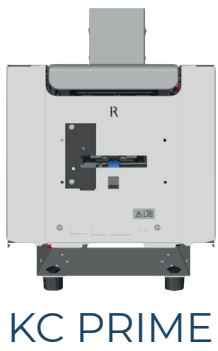

- 9 Remove the film from the adhesive card ① and insert the cleaning card into the feeder as shown, adhesive side up ②. Cleaning starts.
- 10 Remove the cleaning card from the output hopper.
- 11 Put the 200-card feeder extension back on the upper feeder part.
- 12 Adjust the card thickness. Please wait for 2 minutes before using your printer again.

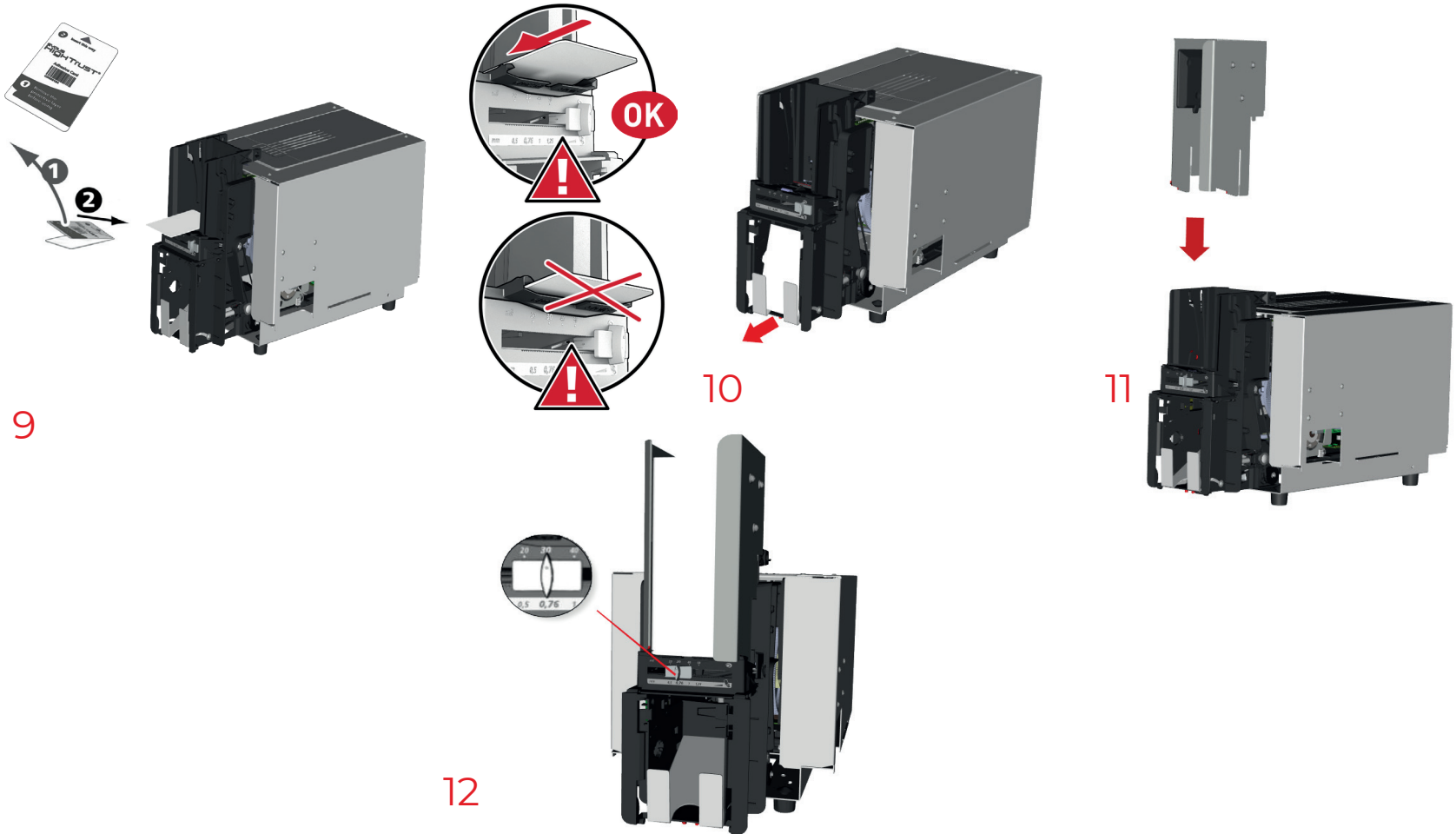

The "T" shaped card must be used immediately after its bag is opened.

If the terminal is in a dusty environment, we recommend that you place a protective cover on the printer to limit exposure to dust, whether the printer is in operational mode or not. For more thorough cleaning, you can also carry out manual cleaning.

The cleaning frequencies recommended by Evolis may be increased depending on the environment in which the terminal is located.

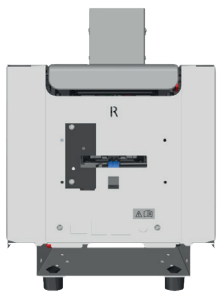

KC PRIME

Servicing the Print Head



Recommended cleaning cycle: whenever the ribbon is changed.

Servicing accessory: special cotton swab impregnated with isopropyl alcohol or cleaning pen.

To maintain the original print quality and to absorb excess ink on the print head, we recommend that you clean the print head regularly (at each ribbon change and periodic cleaning) using the cotton swabs provided by Evolis. You must also protect the print head and its components from any electrostatic discharge.



Follow the cleaning cycles scrupulously.

Avoid any contact between the print head and any metal or sharp objects.

Avoid touching the print head directly with your fingers, as this could affect print quality or permanently damage the print head.

Follow the procedure below:

- 1 Take an Evolis cotton swab and press the middle of the tube until the end of the swab is soaked in alcohol.
- 2 Open the cover and locate the print head.
- 3 Gently rub the swab from left to right along the print head for a few seconds.
- 4 Close the cover.

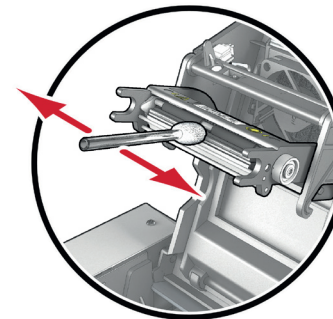

Wait for 2 minutes after cleaning before using your printer.

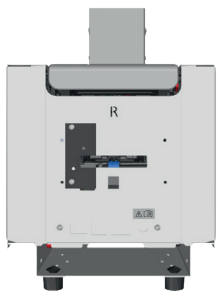

KC PRIME

Maintenance of the dust filter

The dust filter is located above the ventilator for the print head. This filter can get dirty over time. We recommend cleaning it once a year or after 10,000 cards, depending on your work environment.

- 1 Open the printer cover. Locate the dust filter.
- 2 Remove the filter by pulling it up and sliding to release it completely.
- 3 Once the filter has been removed from its place, take one of the cleaning wipes supplied by Evolis.
- 4 Clean the filter by wiping each side of it.
- 5 To put it back, insert it in place (groove facing you) and push it down until it clicks into position.
- 6 Close the cover.

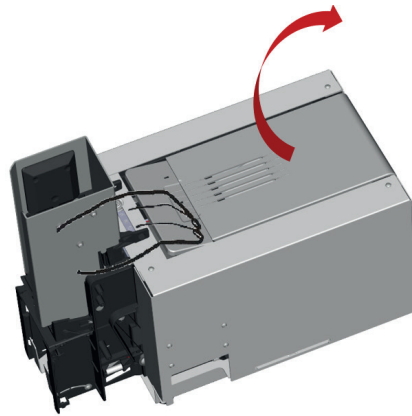

1

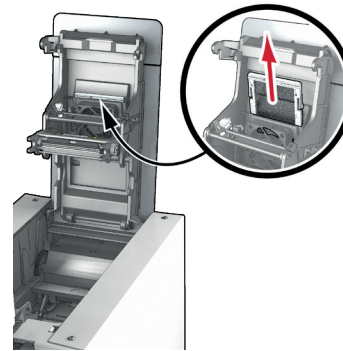

2



3

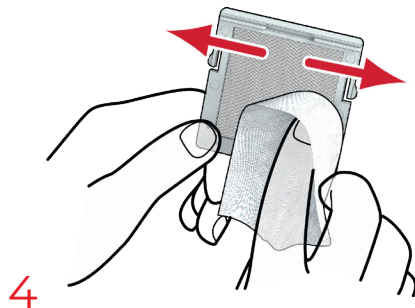

4



5

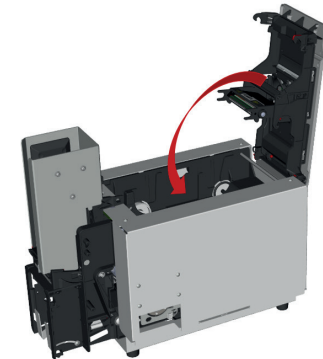

6

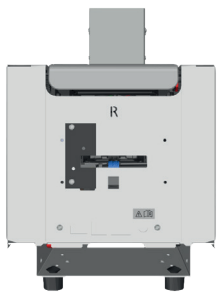

KC PRIME

APPLICATION DEVELOPMENT

In a Windows environment, we expressly recommend that you use the Premium SDK to develop the software application.

The Premium SDK is designed for developers who want to communicate with one or several Evolis printers from their own software environment, while benefitting from the key functionalities of the Evolis Premium suite.

For other architectures, please use SDK 2.5.



With SDK 2.5, the EPS must be installed in minimal mode, in order to avoid communication conflicts.

We strongly encourage you to use a single communication mode when designing a process. Please use Premium SDK or SDK 2.5 but do not mix programming modes.

Mixing programming modes may cause conflicts during communication with the printer: one communication mode is synchronous (via iomem.dll), whereas the other is asynchronous (via the print spooler).

For more information, go to myplace.evolis.com.



Make sure that the pool of Evolis printers has the latest version of the firmware.



KC PRIME

3.APPENDIX A

DECLARATIONS OF CONFORMITY KC PRIME

In this section, you will find the certifications for your Evolis printer.

Declarations of Conformity

Concerning the Safety and Electromagnetic Compatibility of Radio Equipment (RED 2014/53/EU, LVD 2014/35/EU, EMC 2014/30/EU Directives) and (RoHS3) 2015/863/EU

Manufacturer name: Evolis
Manufacturer address: 14, avenue de la Fontaine
Z.I. Angers Beaucouzé
49070 Beaucouzé, France

Equipment name: KC Prime
Year of manufacture: 2022

I, the undersigned,
Mr. **Laurent Godard**,

Declare under my own responsibility that the product described above is in conformity with the essential applicable requirements of the following directives: **RED 2014/53/EU, LVD 2014/35/EU, EMC 2014/30/EU, and (RoHS3) 2015/863/EU:**

Article 3.1 a: (electromagnetic compatibility protection requirement)

Safety standard applied EN62368-1 :2014
EN50364: 2010

Article 3.1 b: (electromagnetic compatibility protection requirements)

EMC standard applied EN55032: 2012
EN55024: 2010
EN61000-3-2: 2014
EN61000-3-3: 2013
EN 301489-3: 2013 (V1.6.1)



Article 3.2: (proper use of the radio spectrum to avoid harmful interference)

EMC standard applied EN300 330-2 V1.6.1

Full name: Laurent Godard

Title: R&D Director

Date: January 4th 2022

Signature:

EUROPE - Norway only: This product is designed for an IT power system with phase-to-phase voltage of 230 V. Earth grounding is via the polarized, 3-wire power cord.

FI: "Laitte on liitettävä suojamaadoitus koskettimilla varustettuun pistorasiaan"

SE: "Apparaten skall anslutas till jordat uttag"

NO: "Apparatet må tilkoples jordet stikkontakt"

DK: "Apparatets stikprop skal tilsluttes en stikkontakt med jord, som giver forbindelse til stikproppens jord".

FCC Federal Communications Commission notice

Radio frequency interference in the United States



The KC Prime model complies with the following specification: FCC Part 15, Subpart A, Section 15.107(a) and Section 15.109(a) Class B Digital device

Additional information:

This equipment has been tested and found to comply with the limits for a Class B digital device, pursuant to part 15 of the FCC Rules. These limits are designed to provide reasonable protection against harmful interference in a residential installation. This equipment generates, uses and can radiate radio frequency energy and, if not installed and used in accordance with the instructions, may cause harmful interference to radio communications. However, there is no guarantee that interference will not occur in a particular installation. If this equipment does cause harmful interference to radio or television reception, which can be determined by turning the equipment off and on, the user is encouraged to try the following measures:

- Reorient or relocate the receiving antenna.
- Move the equipment away from the radio or television.
- Connect the equipment to a circuit other than that to which the receiver is connected.
- Consult the supplier or an experienced radio/TV technician.

Use of a shielded twisted pair cable is necessary to comply with the restrictions laid down by part 15 of the FCC Rules for Class B digital devices.

Pursuant to Part 15.21 of the FCC Rules, any changes or modifications made to this equipment without the express, written consent of the company Evolis may cause harmful interference and void the FCC authorization to operate this equipment.

We recommend keeping a distance of 20 cm between the user and the RFID module when it is in operation.

This device is compliant with the RSS of Industry Canada applicable to radio devices exempt from licensing. Its use is authorized under the following two conditions: (1) The device must not cause jamming and (2) the device user must accept any radio-electrical jamming it experiences, even if this compromises its operation.

Japanese radio frequency interference (VCCI)

This equipment is Class B information technology equipment based on the rules laid down by the Voluntary Control Council For Interference by Information Technology Equipment (VCCI). Its use in or close to a residential area may cause radio interference. If this occurs, you must take appropriate steps.



この装置は、情報処理装置等電波障害自主規制協議会（VCCI）の基準に基づくクラスB情報技術装置です。この装置は、家庭環境で使用することを目的としていますが、この装置がラジオやテレビジョン受信機に近接して使用されると、受信障害を引き起こすことがあります。取扱説明書に従って正しい取り扱いをして下さい。



이 기기는 업무용(A급) 전자파적합기기로서 판매자 또는 사용자는 이 점을 주의하시기 바라며, 가정외의 지역에서 사용하는 것을 목적으로 합니다.