

evolIS

Identify what matters

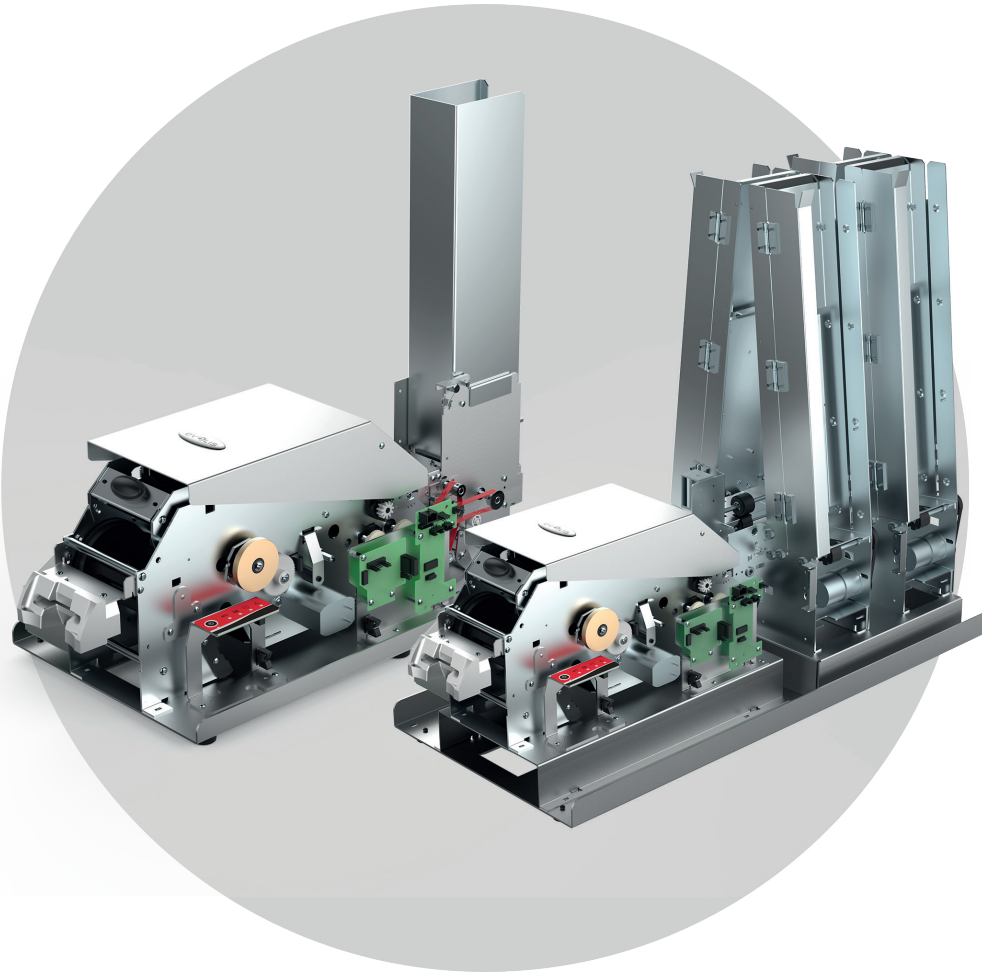

KM500B
KM2000B

USER GUIDE

Evolis © 2022. All rights reserved.

User-guide_KSM1_ENG_20220419_B0

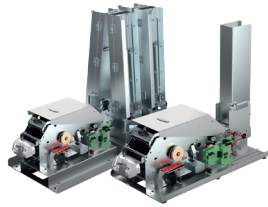

KM500B
KM2000B

TABLE OF CONTENTS

Copyright	4
Trademarks	4
Warranty	4
Environmental Information	4
Recycling End-of-life Products	4
About Your New Printer	5
Getting Started	5
Icons	5
1. GETTING STARTED	6
Unpacking	6
Description of the Printer and Its Functions	7
Description of the Printer and Its Functions	8
KM500B	8
Description of the Printer and Its Functions	9
KM2000B	9
INSTALLATION IN A TERMINAL	10
Physical attachment	10
INSTALLATION IN A TERMINAL	11
Connecting the printer	11
Ribbons	12
Cards	14
2. SERVICING	18
General Warranty Information	18
Routine Printer Cleaning	19
Printer Servicing	19
Maintenance of the cleaning rollers	22
Servicing of the print head	24
APPLICATION DEVELOPMENT	26

TABLE OF CONTENTS

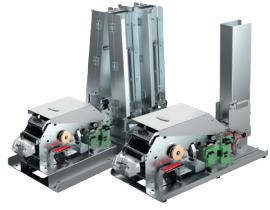

KM500B
KM2000B

3. APPENDIX A	27
Technical specifications	27
1. APPENDIX B	31
Declarations of Conformity KM500B	31
Declarations of Conformity KM2000B	32

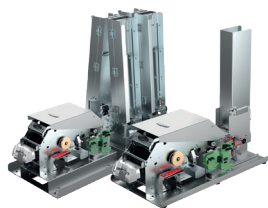

KM500B
KM2000B

COPYRIGHT

Evolis © 2022. All rights reserved.

Users must observe the copyright regulations applicable in their country. This manual must not be photocopied, translated, reproduced, or transmitted, in whole or in part, for any reason and by any electronic or mechanical means whatsoever without the express written consent of Evolis.

All the information contained in this document is subject to change without prior notice.

Evolis cannot be held liable for any errors that may be found in this manual, or for any loss or damage arising accidentally or as a result of dissemination or use of this manual.

TRADEMARKS

Evolis Premium Suite® and Evolis High Trust® are trademarks of Evolis. All other trademarks belong to their respective holders.

WARRANTY

Refer to the warranty notice supplied with your printer for the terms and conditions and limitations. It is available on myplace.evolis.com.

Register online at myplace.evolis.com to receive our special offers and general information.

ENVIRONMENTAL INFORMATION

Evolis is committed to helping the environment by reducing the energy consumption of its products.

RECYCLING END-OF-LIFE PRODUCTS

Manufacturing the equipment that you have purchased required the extraction and use of natural resources. This equipment may contain materials that are hazardous to health and the environment.

To prevent the dispersal of such materials into our environment and reduce pressure on our natural resources, we recommend that you use existing collection facilities. These systems will re-use or recycle most of the materials in your end-of-life equipment in an appropriate way.



The crossed-out dustbin symbol on your device is a reminder to use these facilities.

For further information on collection, re-use, or recycling systems, please contact your local or regional waste management organization.

You can contact us to find out more either by visiting our website www.evolis.com or by writing to the following address: info@evolis.com.



KM500B
KM2000B

ABOUT YOUR NEW PRINTER

Using your new Evolis printer, you can create a wide variety of high-quality cards and personalized badges that can be printed and laminated in various thicknesses, colors, and styles. This printer uses consumables and accessories available from Evolis. For further details, visit our website at www.evolis.com.

GETTING STARTED

The purpose of this guide is to support you, step by step, in discovering your printer and how it works. Please take some time to read it, to learn more about your printer and its features, and to save time during installation and use.

As with all Evolis products, a great deal of care has been taken over this manual. If, however, you find an error in these pages, please let us know by emailing us at info@evolis.com.



Please read this manual carefully.

ICONS

The following icons are used in this manual to highlight important information:



Information providing further details about certain points in the main text.



Indicates that failing to take the recommended action is likely to damage your printer.



This symbol links to Evolis Print Center, accessible from your computer, which you can use to administer and manage your printer and change its settings.

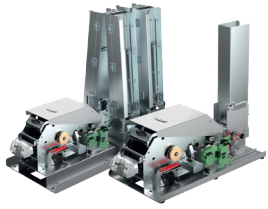

KM500B
KM2000B

1. GETTING STARTED

UNPACKING

Your printer is supplied with several accessories that should be checked on receipt.

The list of accessories may vary depending on your location.

The printer is shipped in special packaging designed to prevent any damage in transit. If you notice any visible damage, please contact the shipping company and immediately inform your Evolis reseller, who will tell you the procedure to follow.

Evolis takes great care over the quality of its packaging and we ask that you keep this packaging somewhere clean and dry.



You will be asked for the full original packaging (outer box, inner wedges, and protective bags) in the event that the printer is returned. If the printer is returned without its original packaging and the components are damaged in transit, these components will no longer be covered by the warranty. A charge will be made for new packaging to reshipe the printer.

Accessories supplied with your printer:

- Power supply unit - CWT type KPL-065M-VI.
- Mains power cable.
- USB cable.
- Installation, documentation, and software CD-ROM.
- Starter cleaning kit.
- Quick installation guide (KM500B).



If any of these components are missing, please contact your Evolis reseller.

Use only the power supply unit provided with your Evolis printer.

CWT type KPL-065M-VI.

Use only the USB cable supplied with your Evolis printer.



The Evolis printer should be placed in a dry place, protected from dust and drafts but well ventilated. Please ensure you keep your printer on a flat, solid surface able to bear its weight.

DESCRIPTION OF THE PRINTER AND ITS FUNCTIONS

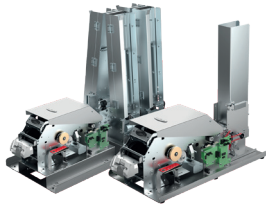

KM500B
KM2000B

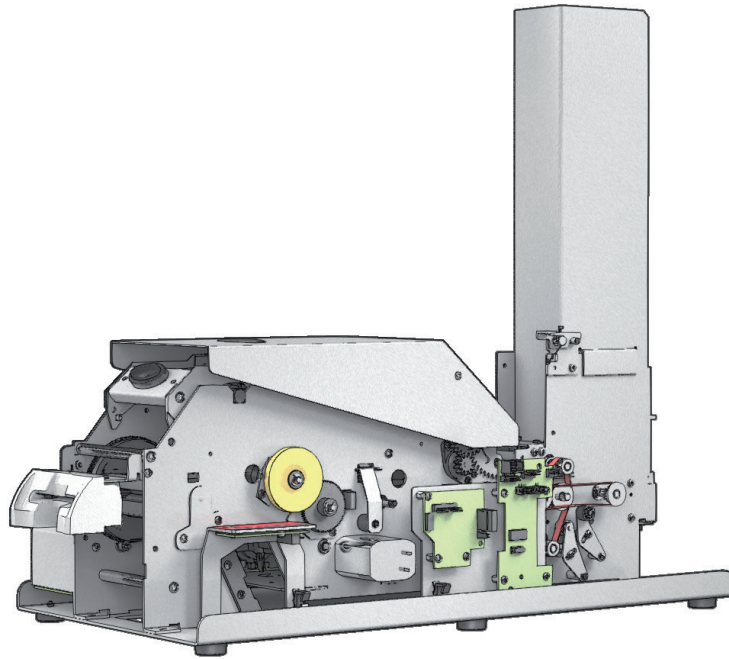

KM500B

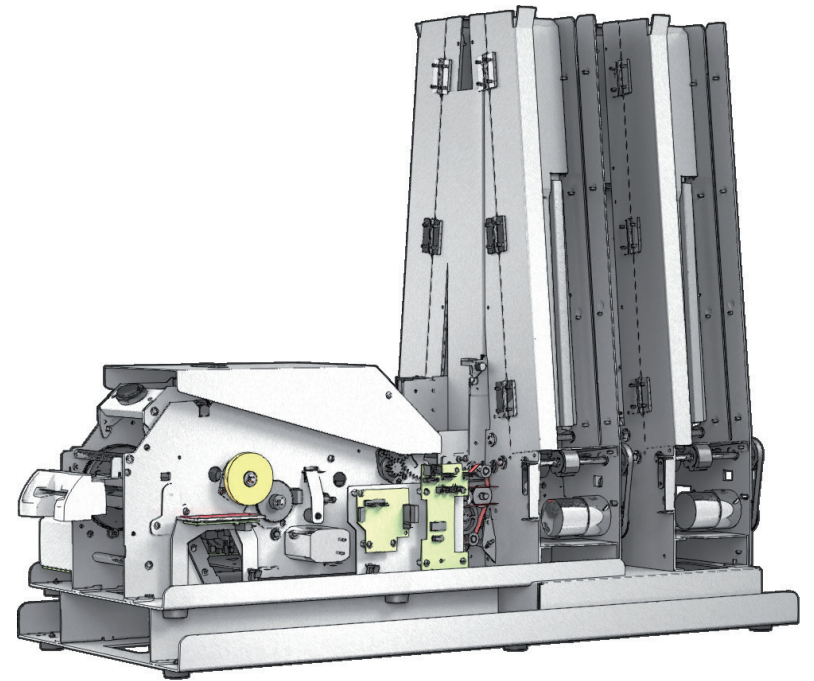

KM2000B



KM500B
KM2000B

DESCRIPTION OF THE PRINTER AND ITS FUNCTIONS

KM500B

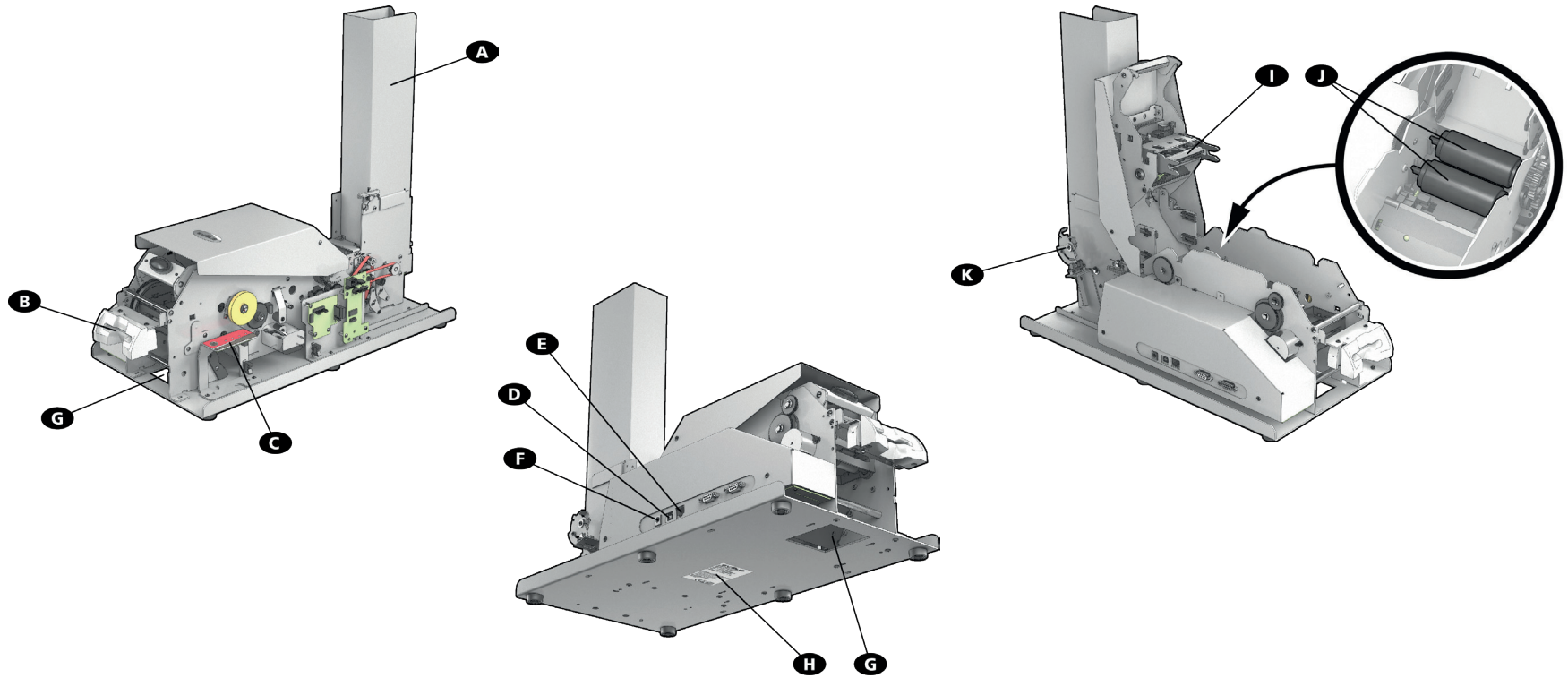

- A Card feeder
- B Bezel: card entry and output
- C Control panel
- D USB port (type A)
- E Ethernet port
- F Power cable socket
- G Ejector slot

- H Serial number label
- I Thermal print head
- J Cleaning rollers
- K Alert gauge for almost-empty cards

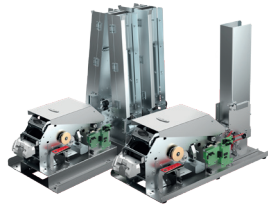

KM500B
KM2000B

DESCRIPTION OF THE PRINTER AND ITS FUNCTIONS

KM2000B

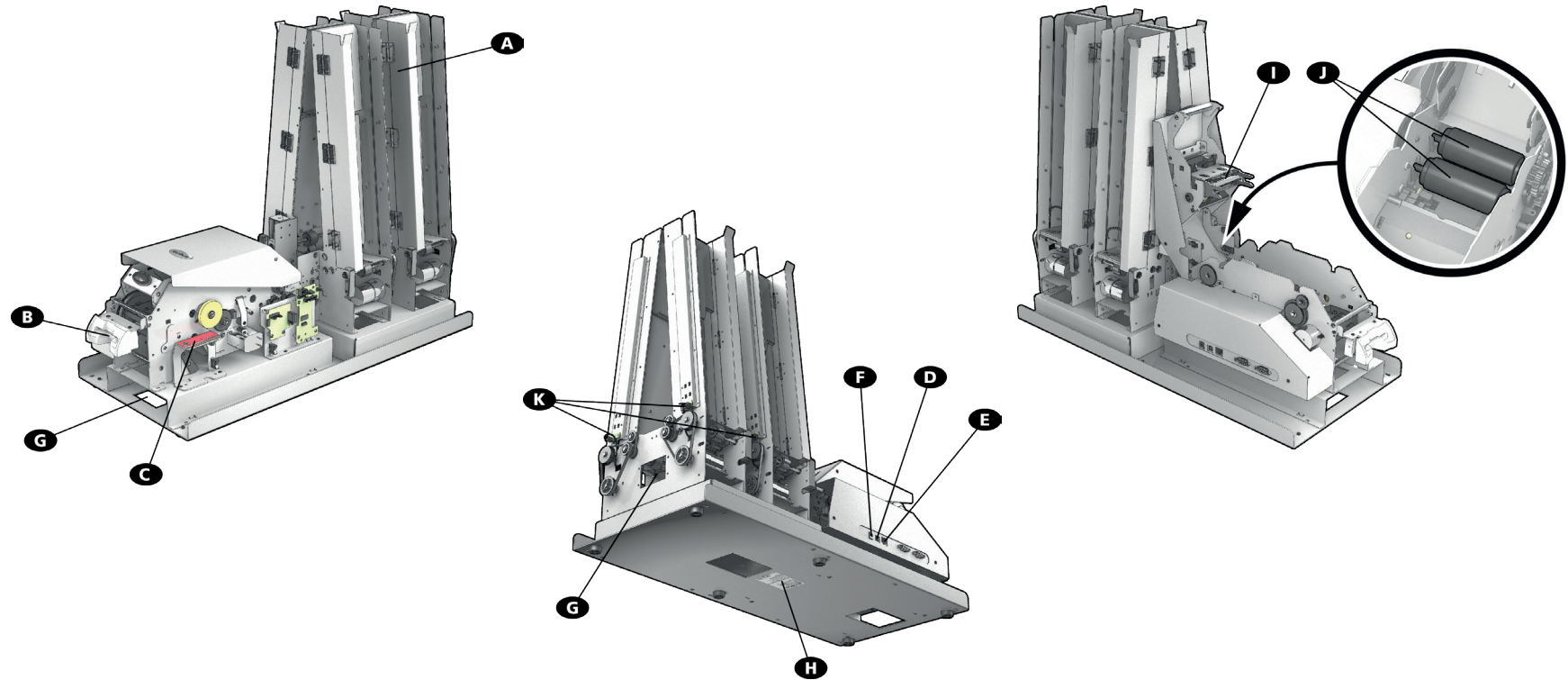

- A Card feeder
- B Bezel: card entry and output
- C Control panel
- D USB port (type A)
- E Ethernet port
- F Power cable socket
- G Ejector slot

- H Serial number label
- I Thermal print head
- J Cleaning rollers
- K Alert gauge for almost-empty cards

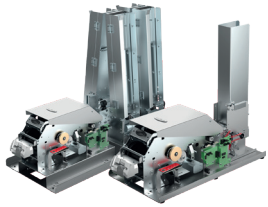

KM500B
KM2000B

INSTALLATION IN A TERMINAL

Physical attachment

The KM500B/KM2000B printers can be attached to the terminal using screws.

To do so:

- 1 Remove the 6 rivet feet from the bottom plate by pressing on them.
- 2 There are slotted holes (5 on each side) on the bottom plate to enable you to attach the printer to the terminal.

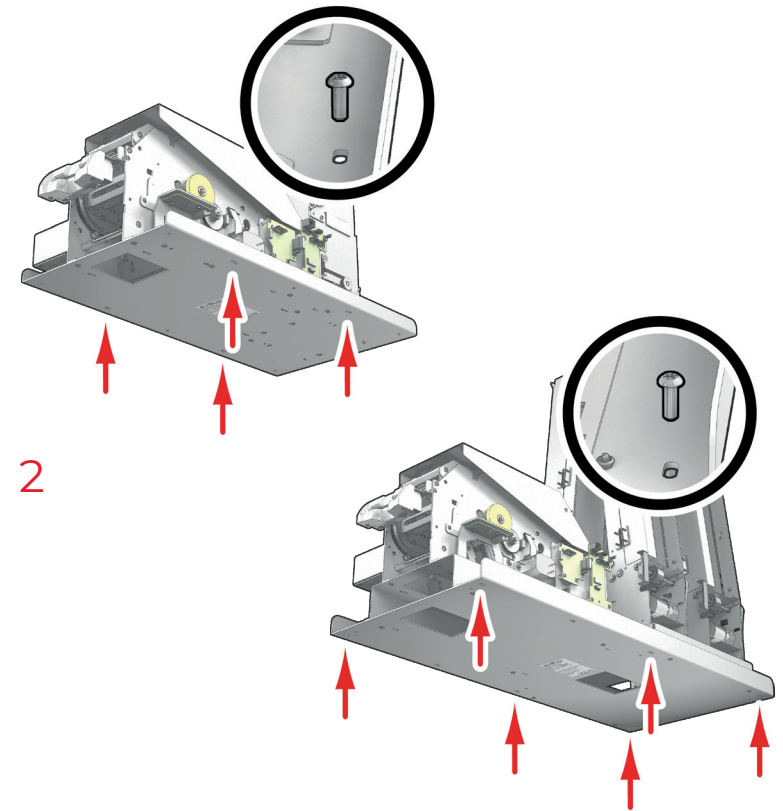
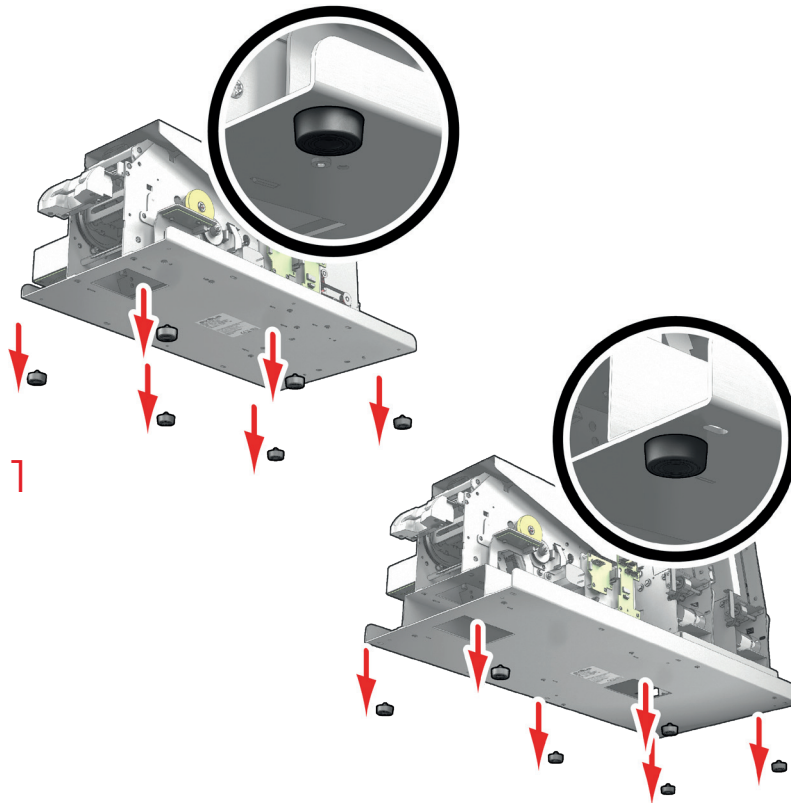

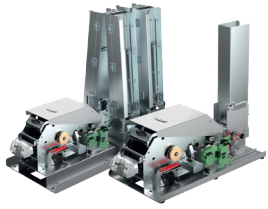

KM500B
KM2000B

INSTALLATION IN A TERMINAL

Connecting the printer



The printer must be connected to a properly protected and grounded electrical system.

FI: Laite on liitettävä suojamaadoitus koskettimilla varustettuun pistorasiaan.

NO: Apparatet må tilkoples jordet stikkontakt.

SE: Apparaten skall anslutas till jordat uttag.

DK: Printeren skal tilsluttes til en korrekt beskyttet og jordforbundet el-installtion.

Connection to the power supply

- Connect the power cable to the power supply unit, then plug the power cable jack into the printer.
- Next, connect the power cable plug to a grounded power socket outside of the terminal.
- The printer is powered on: the control panel lights up indicating that the printer is working properly. If the control panel does not light up, then either the installation has not been carried out correctly or the printer is not working properly. Check the installation.

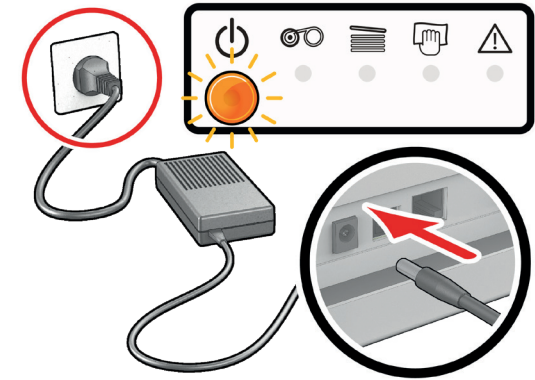

For your personal safety, ensure that the cable and power supply unit can be easily accessed, especially in an emergency.



KM500B
KM2000B

Ribbons

Evolis original High Trust® ribbons optimize the operation of your printer and avoid causing damage to it. The use of ribbons from other suppliers is likely to damage your printer and will void the manufacturer's printer warranty.

For optimum print quality, Evolis recommends that the printer is fully cleaned every time the ribbon is changed.

See «2. Servicing», page 18.

Fitting the ribbon – KM500B



In the printer driver, make sure that the selected ribbon type is appropriate.

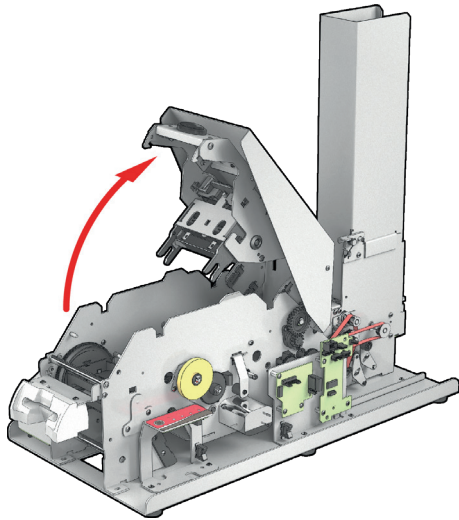

Open the cover on your printer.

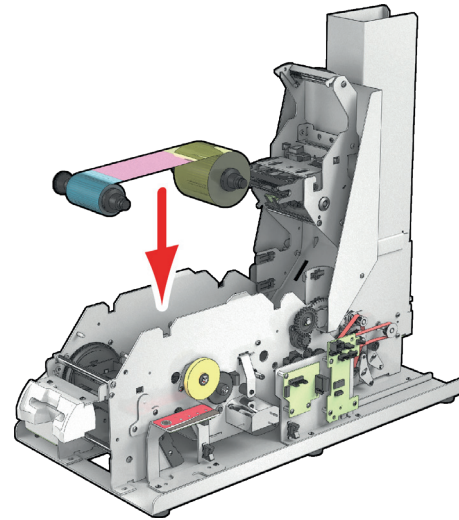

Insert the ribbon as shown.

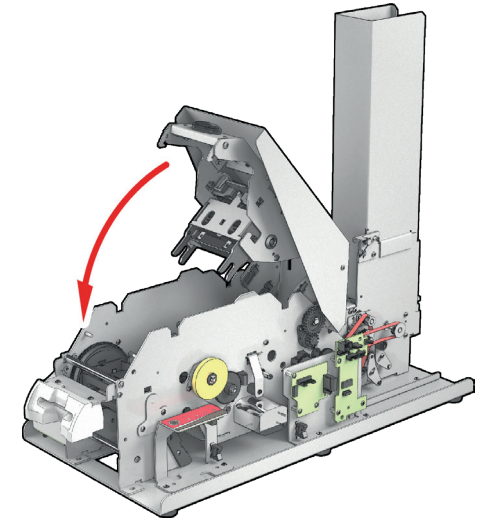

Close the cover and press until you hear a click.



In the Evolis Print Center you can also set the type of ribbon inserted in the machine.

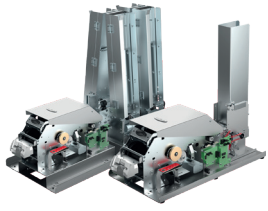

Fitting the ribbon – KM2000B

NOTE

In the printer driver, make sure that the selected ribbon type is appropriate.

KM500B
KM2000B

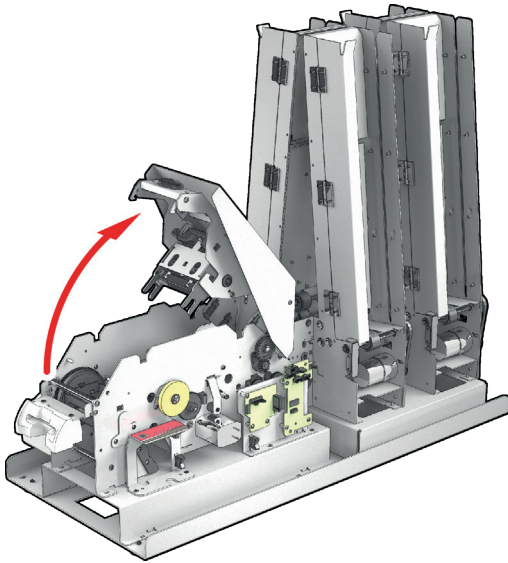

Open the cover on your printer.

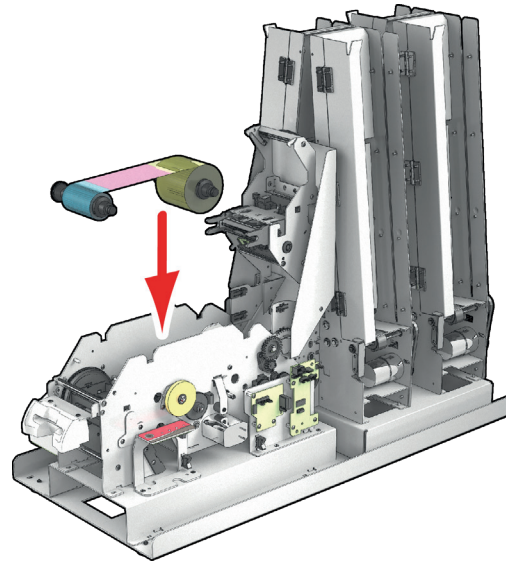

Insert the ribbon as shown.

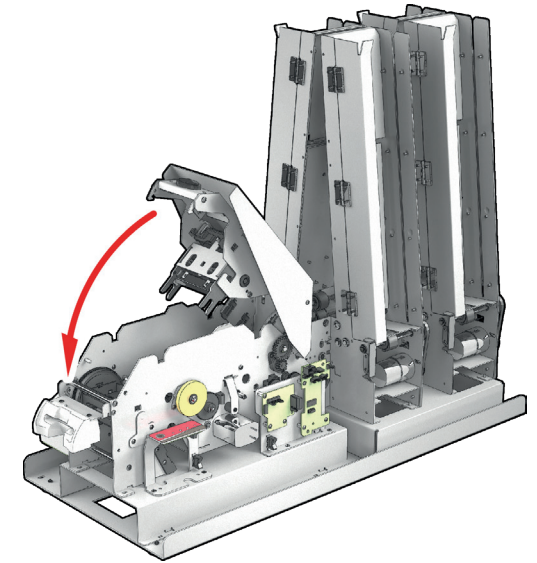

Close the cover and press until you hear a click.



In the Evolis Print Center you can also set the type of ribbon inserted in the machine.

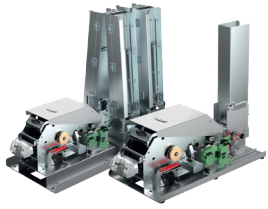

KM500B
KM2000B

Cards



For optimum quality, the cards used must be ISO 7810 certified.

Use only the card types recommended by Evolis.

Avoid touching the printable surface of the cards in order to preserve print quality.

Do not use cards that have been damaged, folded, embossed, or dropped on the floor.

Cards may be stuck together due to static electricity – avoid touching the card surface when separating them.

Storing new cards

Keep your cards protected from dust in their original packaging.

Loading the cards – KM500B

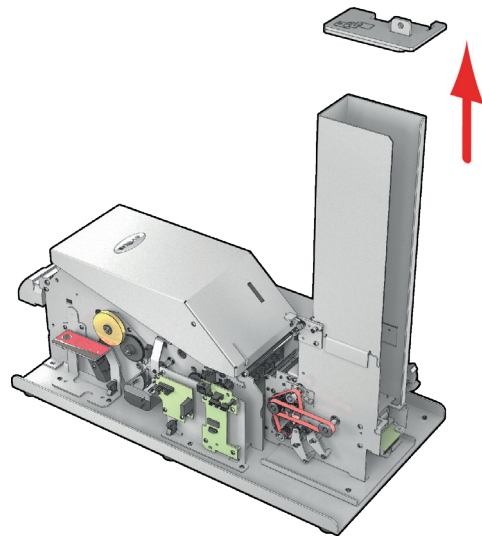

Remove the weight from the feeder.

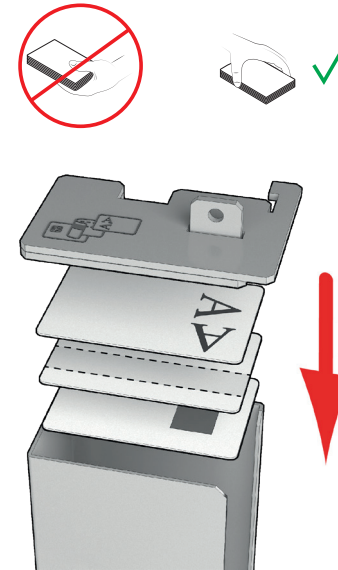

Insert the cards, 500 cards maximum with 0.76 mm thickness.
Hold and insert the cards as shown in the diagram.
Put the weight back on the inserted cards.

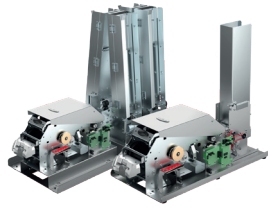

KM500B
KM2000B

Loading the cards – KM2000B

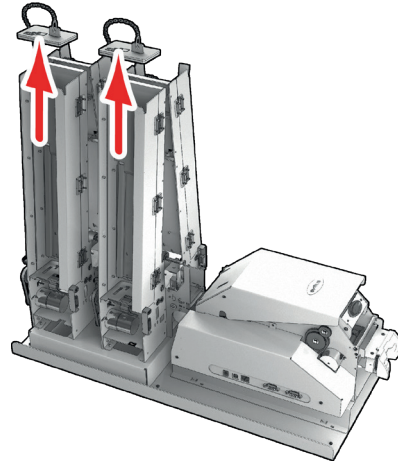

Remove the weights from the feeders.

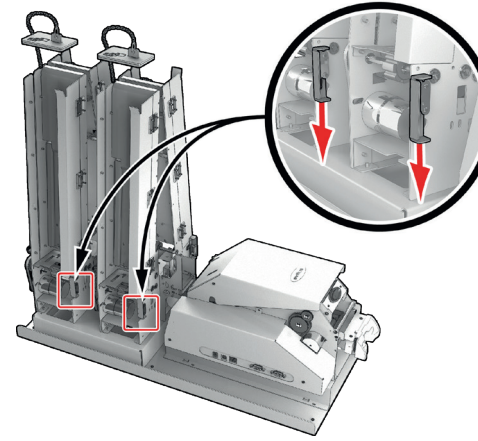

Unlock the latches on each feeder.

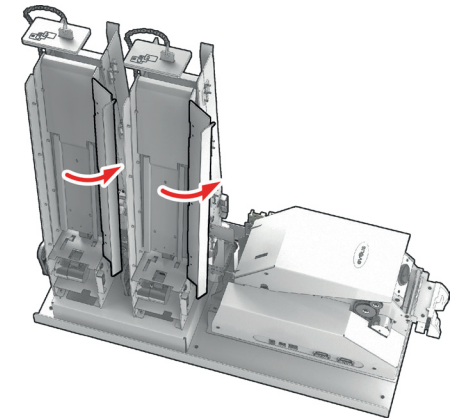

Then open the doors of the feeders.

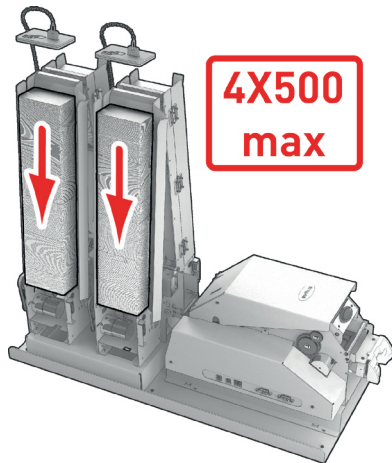
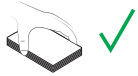

Insert the cards, 500 cards maximum with 0.76 mm thickness. Hold and insert the cards as shown in the diagram.

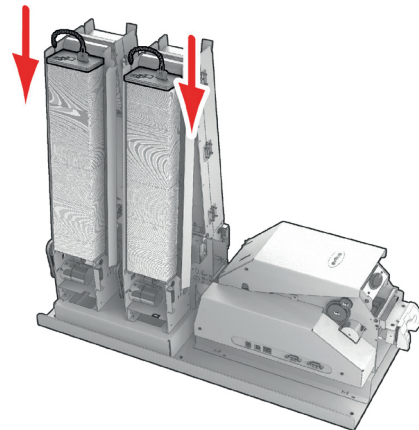

Put the weights back on the inserted cards.

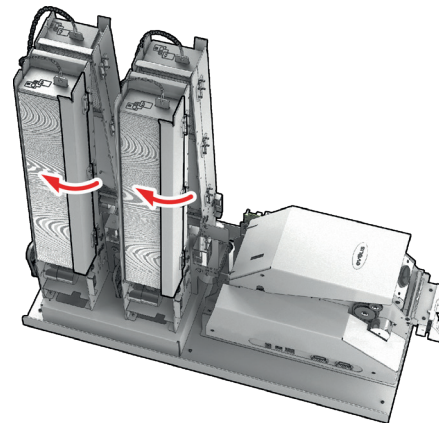

Close the doors.

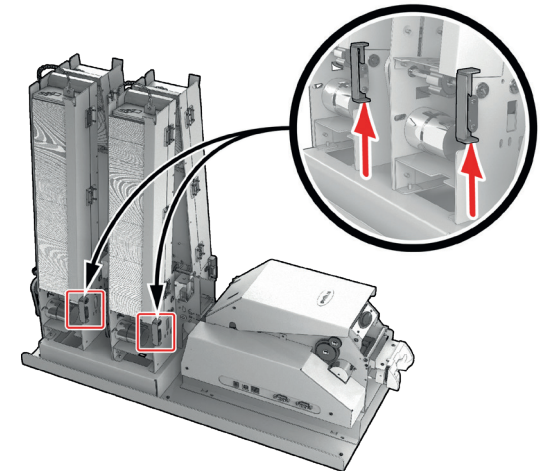

Then lock the latches on each feeder.



KM500B
KM2000B

Managing the almost-empty alert gauge

You can set the alert threshold of the almost-empty gauge for the cards differently for each machine.

KM500B

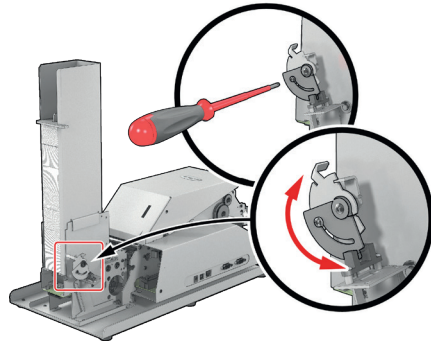

The alert thresholds of the almost-empty gauge are between 0 and 50 cards.

Take a suitable screwdriver and unscrew the screw from the bottom of the gauge and move the triangular plate as required. Then retighten the screw.

KM2000B

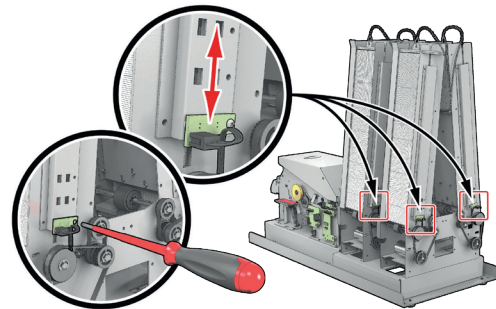

Each charger has an almost-empty sensor on its side.

You can therefore set up each feeder differently.

There are three alert thresholds:

- 1 When the sensor is at the last level (lowest), the alert will be triggered when 20 cards in CR80 format, thickness 0.76 mm, remain in the feeder.
- 2 When the sensor is at the middle level, the alert will be triggered when 40 cards in CR80 format, thickness 0.76 mm, remain in the feeder.
- 3 When the sensor is at the highest level, the alert will be triggered when 60 cards in CR80 format, thickness 0.76 mm, remain in the feeder.

Take a suitable screwdriver and unscrew the screw from the sensor card on the side of the feeder. Move and position the sensor to the level you want. Then retighten the screw.



KM500B
KM2000B

Removing printed cards

Once the print cycle is complete, the printed and/or encoded card is issued through the bezel.

It is possible to retract a printed card that has not been collected by the end customer or is defective after a certain time (configurable duration).

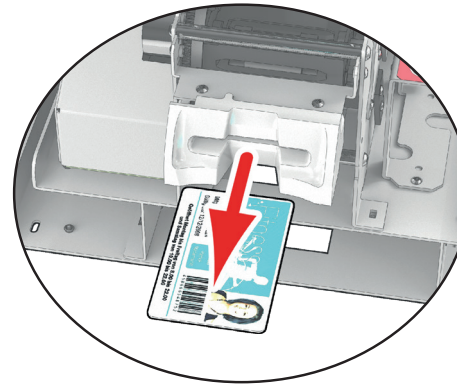

Managing cards with errors

Cards with errors are rejected through the slot in the bottom plate at the front (under the double-sided module).

For the KM2000B printer, it is also possible to eject the cards with errors at the back of the four feeders as soon as an error occurs during loading.

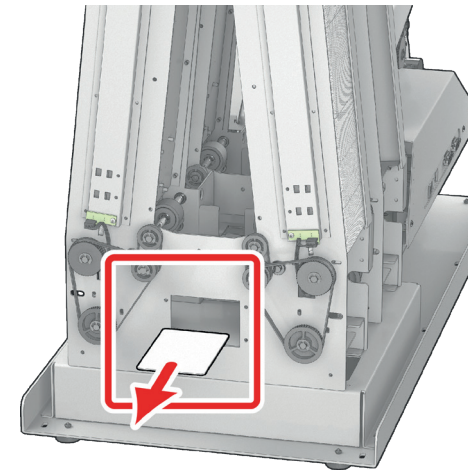
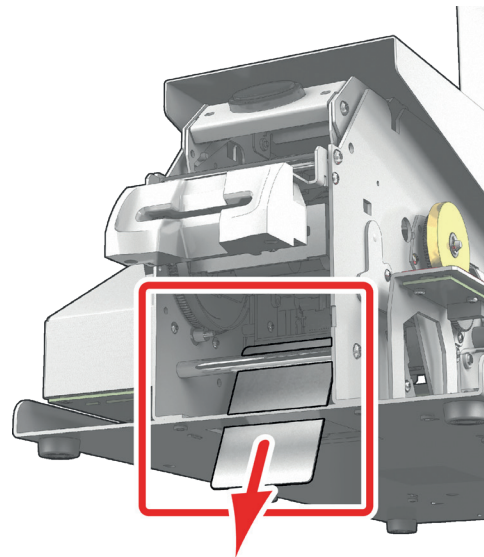

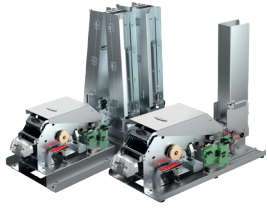

KM500B
KM2000B

2.SERVICING

GENERAL WARRANTY INFORMATION

Please comply with the instructions given below to ensure that your printer runs satisfactorily.

Keep your warranty cover!



The manufacturer's warranty is subject to strict adherence to the routine servicing and maintenance instructions, and in particular the printer cleaning cycles.

Any failure to follow the servicing procedures described in this chapter will void the print head warranty.

Evolis declines any liability where there has been a failure to carry out required maintenance on the printer.

The print head is a wearing part and an extremely sensitive printer component. Its useful life can be seriously curtailed by the presence of dust, liquids or solids in the printer's immediate environment, on the print head or on the cards. The user must take all necessary precautions to insert into the printer only clean, dust-free cards that are free of foreign bodies.

The frequency and quality of cleaning are decisive factors enabling users to extend the print head's useful life and to ensure excellent print quality. Particular care must therefore be taken with cleaning. Users must comply with the servicing and maintenance instructions provided in this chapter.

In addition, the use of Evolis brand ribbons (Evolis High Trust®) also ensures that your equipment operates properly. Use of ribbons not approved by Evolis may affect the quality and reliability of print jobs, produce low quality printing, and even affect how the printer operates. The manufacturer's warranty does not cover physical damage or quality problems caused by using non-Evolis approved ribbons.

Evolis supplies the maintenance items and consumables. You can find them on the website www.evolis.com.



KM500B
KM2000B

ROUTINE PRINTER CLEANING

Printer Servicing



The print head warranty is directly linked to routine cleaning of your printer.
If you do not carry out this cleaning at the required times, the print head warranty will cease to be valid.



Recommended cleaning cycle: whenever the ribbon is changed
Mandatory cleaning cycle: when the cleaning warning is triggered
Servicing accessories: impregnated cleaning card.



Your printer is equipped with a cleaning alert system that is activated after a certain number of cards are inserted.
You should proceed with the routine cleaning of your printer as soon as the warning is triggered.
If you continue to run the printer despite the warning and if the warning light remains lit, the print head warranty will be automatically voided because of failure to comply with contractual maintenance obligations.

Printer cleaning required after: (warning light flashing)	Number of cards remaining before warranty voided: (warning light flashing)	Warranty invalid after: (warning light steady)
1,800 cards	500 cards	2,300 cards



KM500B
KM2000B

Follow the procedure below to validate your routine cleaning:

Repeatedly passing the card impregnated with isopropyl alcohol through the printer cleans the cleaning roller in order to preserve print quality and increase the life of the print head.

- 1 Lift the weight and remove all cards from the feeder (KM500B) or from one feeder (KM2000B).
- 2 Remove the ribbon from the printer.
- 3 Close the cover again.

KM500B

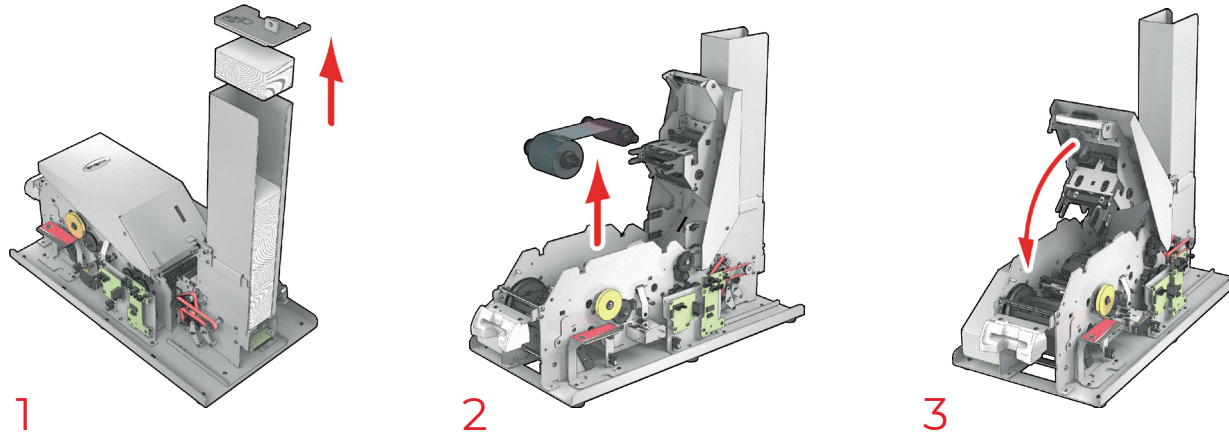

KM2000B

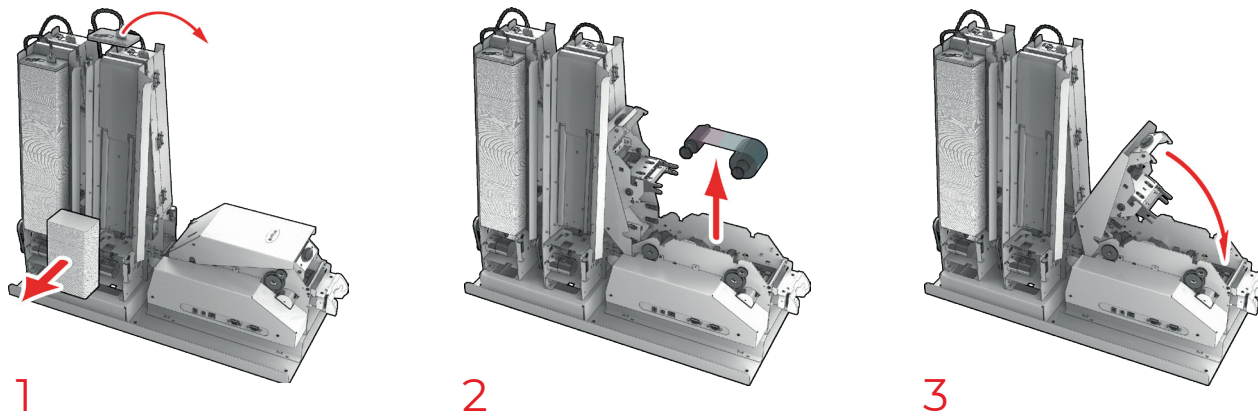



KM500B
KM2000B

- 4 Remove the cleaning card from its envelope and place it in the feeder. Place the feeder weight on it.
- 5 Double-click on the push button on the control panel. The cleaning LED starts flashing. Cleaning starts.
- 6 Remove the cleaning card through the ejector slot on the bottom plate of the printer.

KM500B

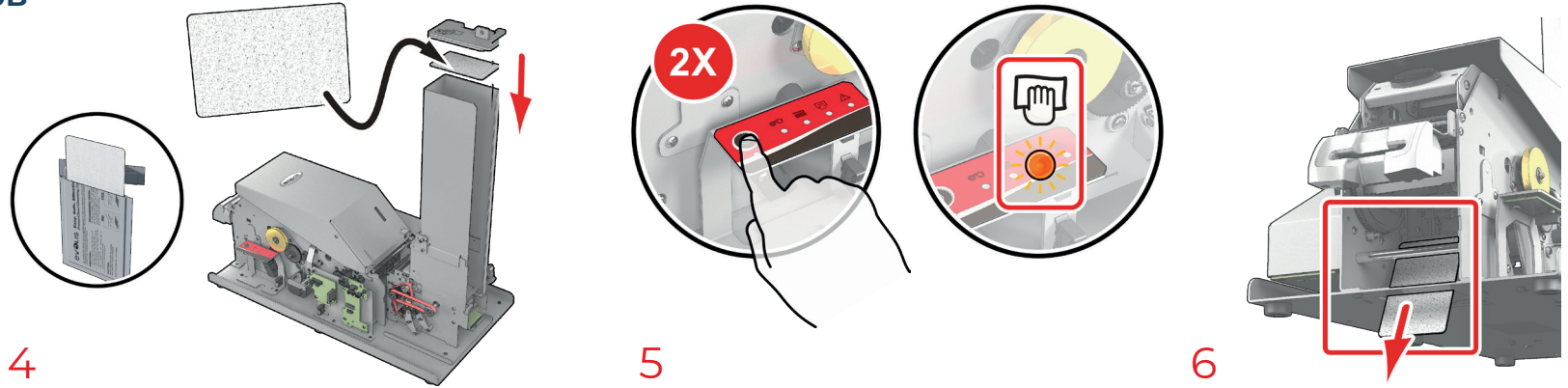

KM2000B

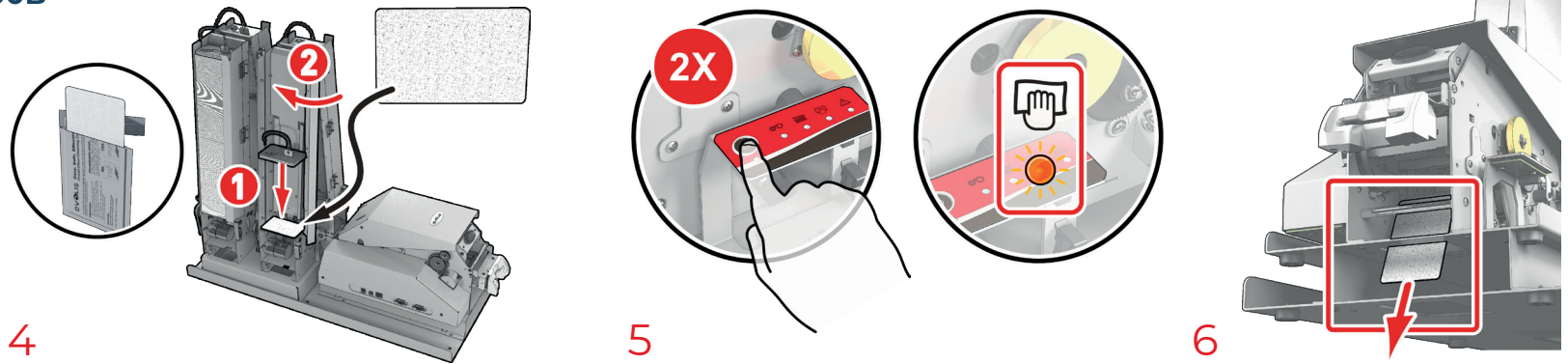

Regular cleaning may also be launched from the Evolis Print Center by clicking on "Start cleaning."



Please note that the impregnated card must be used immediately after the bag is opened.



Wait for 2 minutes after cleaning before using your printer.

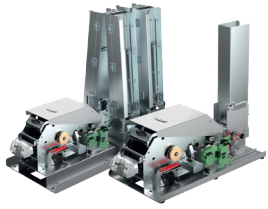

KM500B
KM2000B

Maintenance of the cleaning rollers

In addition to cleaning the printer, we encourage you to clean the two cleaning rollers using the specific cleaning wipes available from Evolis. These rollers remove any dust on the cards before printing.

NOTE

Recommended cleaning cycle: whenever the ribbon is changed

Servicing accessory: cleaning wipe

Follow the procedure below:

- 1 Open the cover and remove the ribbon if required.
- 2 Remove the two cleaning rollers. Clean one after the other.
- 3 Use a cleaning wipe provided by Evolis and lightly rub the surface of the roller with the cleaning wipe.

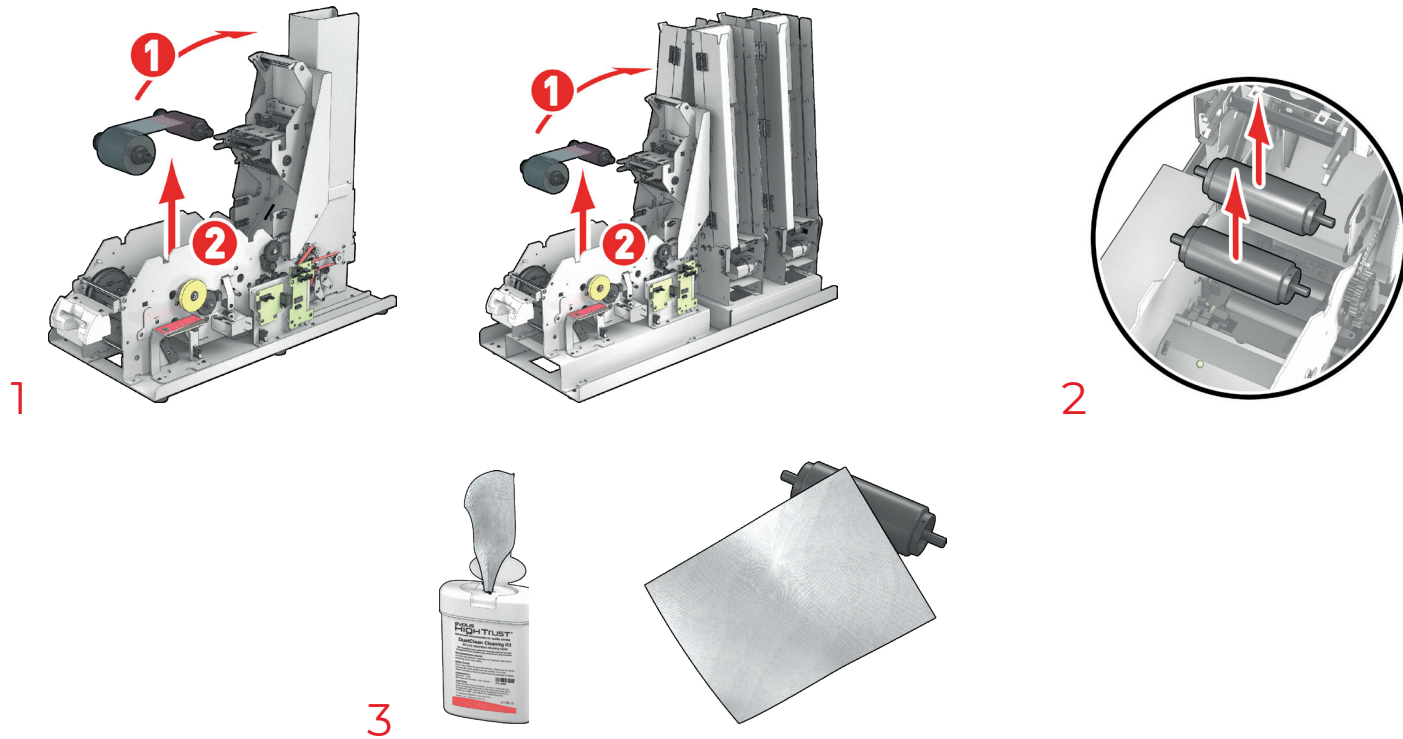

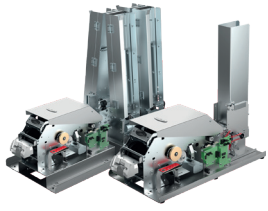

KM500B
KM2000B

- 4 When the roller is dry, replace the cleaning roller. Repeat the procedure for the second roller.
- 5 Then replace the ribbon if necessary and close the printer cover.

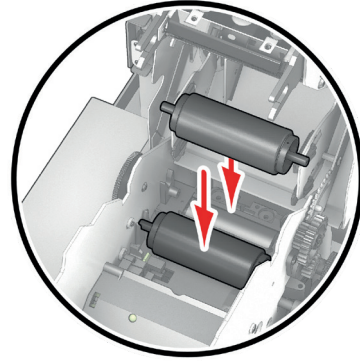

4

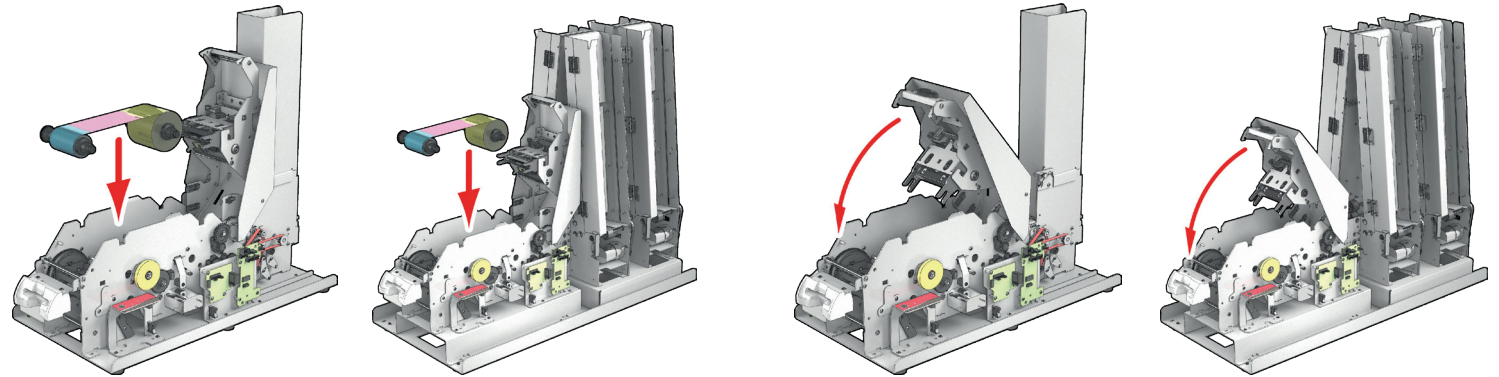

5



Wait for 2 minutes after cleaning before using your printer.

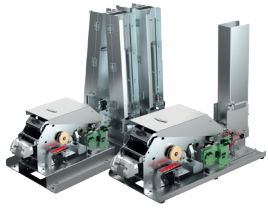

KM500B
KM2000B

Servicing of the print head



Recommended cleaning cycle: whenever the ribbon is changed.

Servicing accessory: special cotton swab impregnated with isopropyl alcohol or cleaning pen.

To maintain the original print quality and to absorb surplus ink on the print head, we recommend that you regularly clean the print head (whenever the ribbon is changed and during regular cleaning) using the swabs supplied by Evolis. You must also protect the print head and its components from any electrostatic discharge.



Follow the cleaning cycles scrupulously.

Avoid any contact between the print head and any metal or sharp objects.

Avoid directly touching the print head with your fingers, as this could affect print quality or permanently damage the print head.

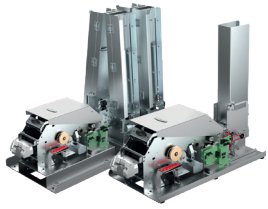

KM500B
KM2000B

Follow the procedure below:

- 1 Take an Evolis cotton swab and press the middle of the tube until the end of the swab is soaked in alcohol.
- 2 Open the cover and locate the print head.
- 3 Gently rub the swab from left to right along the print head for a few seconds.
- 4 Close the cover.



1

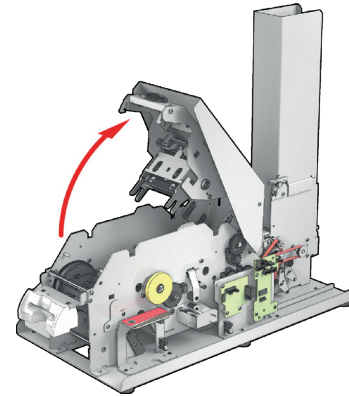

2

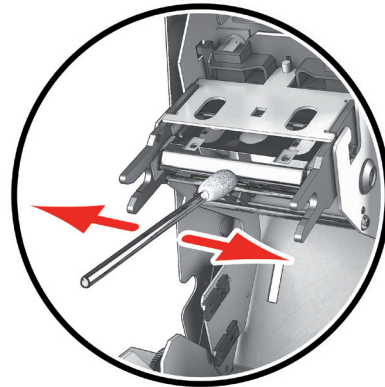
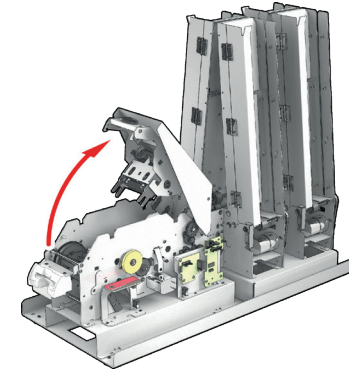

3

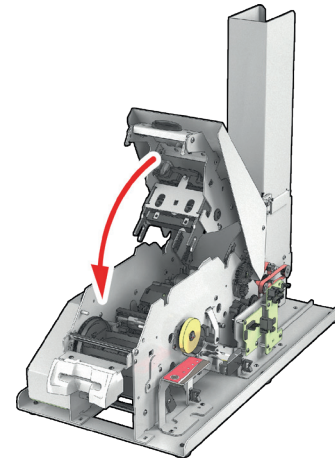

4

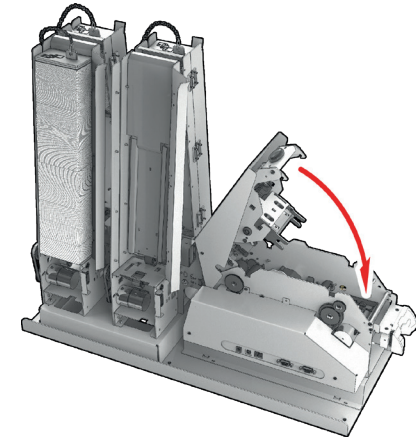

Wait for 2 minutes after cleaning before using your printer.



KM500B
KM2000B

APPLICATION DEVELOPMENT

We expressly recommend that you use the Premium SDK to develop the software application in a Windows environment.

The Premium SDK is designed for developers who want to communicate with one or several Evolis printers from their own software environment, while benefitting from the key functionalities of the Evolis Premium suite.

For the other environments, other tools are available (SDK2.5, etc.).



If other tools are used, for example: SDK 2.5, the EPS must be installed in minimum mode, in order to avoid communication conflicts.

We strongly encourage you to use a single communication mode when designing a process.

Mixing communication modes may cause conflicts during communication with the printer, so it is important to be very careful: one communication mode is synchronous (communication via iomem.dll) whereas the other is asynchronous (communication via the print spooler).

If a combination of communication modes is used, synchronization between the application and the print spooler must take place.



Make sure that the pool of Evolis printers has the latest version of the firmware.

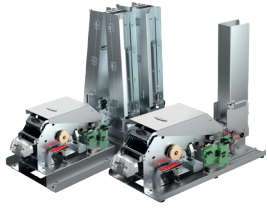

KM500B
KM2000B

3.APPENDIX A

TECHNICAL SPECIFICATIONS

This section presents your printer's technical printing properties.

General features

- Color sublimation directly on the card / Resin thermal transfer
- Double-sided printing, edge-to-edge
- ISO 7811 HiCo/LoCo magnetic stripe encoding
- Contact station for smartcard
- Standard resolution 300 x 300 dpi
- 16 MB memory (RAM)

Print speed

Single-sided:

- Color (YMCKO) – 30 s per card
- Monochrome – 9 s per card

Double-sided:

- (YMCKO-K) – 38.5 s per card

Card loading and returning

- KM500B: One 500-card feeder
- KM2000B: Four 500-card feeders
- Manual insertion and return with bezel
- Reject slot for faulty cards
- Capacity to take back uncollected cards

Card characteristics

- Card thickness: 0.76 mm (30 mil)
- Card types: PVC cards, composite PVC cards, PET cards, ABS¹ cards, and special varnishes¹
- Card format: ISO CR80 – ISO 7810 (53.98 mm x 85.60 mm)

¹ In special conditions

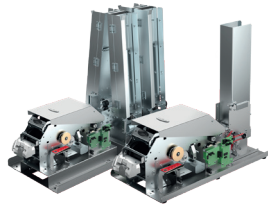

KM500B
KM2000B

Ribbons

To maximize the quality and lifetime of the printed cards, the service life of the print head, and the overall reliability of your printer, use Evolis High Trust® ribbons.

- Ribbon capacity:
- YMCKO: 500 prints/roll
- YMCKO-K: 500 prints/roll
- ½ YMCKO: 400 prints/roll
- KO: 500 prints/roll
- KO: 1,500 prints/roll
- Monochrome black ribbon: 3,000 prints/roll¹
- Other monochrome ribbons: 1,000 prints/roll¹
- BlackFlex (for ABS and special varnishes): 1,000 prints/roll
- Integrated ribbon saving for monochrome printing

¹ In special conditions

Ports/connectivity

- USB (1.0, 1.1, 2.0, 3.0)
- Ethernet TCP-IP 10BaseT, 100BaseT (Traffic Led)
- Option on request: serial port

Display

- LEDs
- Graphical printer notifications: cleaning alerts, card feeder alert, and ribbon empty/almost empty

Software

- Compatible with Windows® (32/64 bits): XP SP3, Vista, W7, W8, W10
- Mac OS X v 10.6 and higher on request
- Linux available on request
- Evolis Premium Suite®:
- Printer driver
- Evolis Print Center for the administration and configuration of the printer
- Evolis Printer Manager for visual notification²
- 24/7 online support
- Free Evolis Premium SDK for monitoring the printer remotely, facilitating and accelerating integration with IT systems

² Requires .net 4.0 client profile



KM500B
KM2000B

Warranty conditions³

- 2 years' warranty (printer and print head)
- Optional extended warranty available

³ Warranty subject to strict compliance with specific usage and maintenance conditions and use of Evolis High Trust® ribbons

Dimensions and weight

- Dimensions (H x W x D):
- KM500B: 492 x 250 x 529 mm, with feet: H: 500 mm
- KM2000B: 571 x 300 x 710 mm, with feet: H: 579 mm
- Weight:
- KM500B: 11.5 kg
- KM2000B: 26.5 kg

Security

- Data encryption for magnetic encoding

Package contents

- Printer
- Power supply unit
- Mains power cable
- USB cable
- Installation, documentation, and software CD-ROM
- Starter cleaning kit.

Additional encoding modules

- Available modules:
- Contact smart card encoder – PC/SC, EMV 2011-1 version 4.3Contact
- Contactless smart card encoder – ISO 14443A, B, ISO14693, MIFARE, DESFire, HID iCLASS
- Other specific encoders on request
- Internal USB or IP connections
- Combinable options

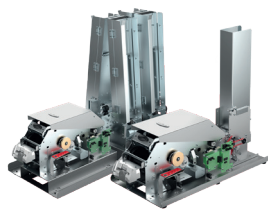

KM500B
KM2000B

Certifications and declarations of conformity

- CE, FCC, ICES, VCCI, EAC, CCC, BIS
- RoHS

Power supply

- Power supply unit: 100-240 volts AC, 50-60 Hz, 1.7 A
- Printer: 24 volts DC, 2.7 A

Environment

- Standard operating temperature and humidity:
- 15° / 30° C (59° / 86° F)
- 20% to 65% non-condensing
- Min/max operating temperature and humidity¹:
- 0° / 40° C (32° / 104° F)
- 20% to 65% non-condensing
- Min/max storage temperature: -5 °C/+70 °C (23 °F/158 °F)
- Storage humidity: 20% to 70% non-condensing
- Ventilation while in operation: free air circulation

¹ Under specific conditions and project qualification

The following icons appear on the printer label to indicate important information:



The equipment is evaluated at an altitude not exceeding 2,000 m; this is the only operating condition that applies to the equipment. There may be a potential safety risk if the equipment is used at an altitude above 2,000 m.



The equipment is evaluated in temperate climatic conditions; this is the only operating condition that applies to the equipment. There may be a potential safety risk if the equipment is used in a region with a tropical climate.

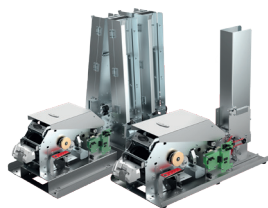

KM500B
KM2000B

4. APPENDIX B

DECLARATIONS OF CONFORMITY KM500B

Declarations of Conformity KM500B

Concerning Safety and Electromagnetic Compatibility of Radio Equipment (Directives LVD 2014/35/EU, EMC 2014/30/EU) and (RoHS3) 2015/863/EU

Manufacturer name: Evolis
Manufacturer address: 14, avenue de la Fontaine
Z.I. Angers Beaucouzé
49070 Beaucouzé, France

Equipment name: KM500B
Year of manufacture: 2022

I, the undersigned,
Mr. **Laurent Godard**,

Declare under my sole responsibility that the product described above is in conformity with the applicable essential requirements of the Directives **LVD 2014/35/EU, EMC 2014/30/EU and (RoHS3) 2015/863/EU**:

Safety standard applied EN62368 -1: 2014

EN62311: 2008

EMC standard applied

EN55032: 2012

EN55024: 2010

EN61000-3-2: 2014

EN61000-3-3: 2013



To this effect, I declare that all radio test series have been carried out.

Full name: Laurent Godard,

Title: R&D Director

Date: January 4, 2022

Signature:

EUROPE - Norway Only: This product is designed for an IT power system with phase-to-phase voltage of 230 V. Earth grounding is via the polarized, 3-wire power cord.

FI: "Laitte on liitettävä suojamaadoitus koskettimilla varustettuun pistorasiaan"

SE: "Apparaten skall anslutas till jordat uttag"

NO: "Apparatet må tilkoples jordet stikkontakt"

DK: "Apparatets stikprop skal tilsluttes en stikkontakt med jord, som giver forbindelse til stikproppens jord".

FCC Federal Communications Commission notice

Radio frequency interference in the United States



The KM2000B model complies with the following specification: FCC Part 15, Subpart A, Section 15.107(a) and Section 15.109(a) Class B Digital device

Additional information:

This equipment has been tested and found to comply with the limits for a Class B digital device, pursuant to part 15 of the FCC Rules. These limits are designed to provide reasonable protection against harmful interference in a residential installation. This equipment generates, uses and can radiate radio frequency energy and, if not installed and used in accordance with the instructions, may cause harmful interference to radio communications. However, there is no guarantee that interference will not occur in a particular installation. If this equipment does cause harmful interference to radio or television reception, which can be determined by turning the equipment off and on, the user is encouraged to try the following measures:

- Reorient or relocate the receiving antenna.
- Move the equipment away from the radio or television.
- Connect the equipment to a circuit other than that to which the receiver is connected.
- Consult the supplier or an experienced radio/TV technician.

Use of a shielded twisted pair cable is necessary to comply with the restrictions laid down by part 15 of the FCC Rules for Class B digital devices.

Pursuant to Part 15.21 of the FCC Rules, any changes or modifications made to this equipment without the express, written consent of the company Evolis may cause harmful interference and void the FCC authorization to operate this equipment.

We recommend keeping a distance of 20 cm between the user and the RFID module when it is in operation.

This device is compliant with the RSS of Industry Canada applicable to radio devices exempt from licensing. Operation is permitted under the following two conditions: (1) The device must not cause jamming and (2) the device user must accept any radio-electrical jamming it experiences, even if this comprises its operation.

Japanese radio frequency interference (VCCI)

This equipment is Class B information technology equipment based on the rules laid down by the Voluntary Control Council For Interference by Information Technology Equipment (VCCI). Its use in or close to a residential area may cause radio interference. If this occurs, you must take appropriate steps.



この装置は、情報処理装置等電波障害自主規制協議会（VCCI）の基準に基づくクラスB情報技術装置です。この装置は、家庭環境で使用することを目的としていますが、この装置がラジオやテレビジョン受信機に近接して使用されると、受信障害を引き起こすことがあります。
取扱説明書に従って正しい取り扱いをして下さい。



이 기기는 업무용(A급) 전자파적합기기로서 판매자 또는 사용자는 이 점을 주의하시기 바라며, 가정외의 지역에서 사용하는 것을 목적으로 합니다.

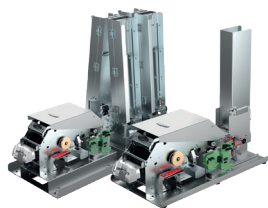

KM500B
KM2000B

DECLARATIONS OF CONFORMITY KM2000B

In this section, you will find the certifications for your Evolis printer.

Declarations of Conformity KM500B

Concerning Safety and Electromagnetic Compatibility of Radio Equipment (Directives LVD 2014/35/EU, EMC 2014/30/EU) and (RoHS3) 2015/863/EU

Manufacturer name: Evolis
Manufacturer address: 14, avenue de la Fontaine
Z.I. Angers Beaucouzé
49070 Beaucouzé, France
Equipment name: KM500B
Year of manufacture: 2022

I, the undersigned,
Mr. **Laurent Godard**,

Declare under my sole responsibility that the product described above is in conformity with the applicable essential requirements of the Directives **LVD 2014/35/EU, EMC 2014/30/EU and (RoHS3) 2015/863/EU**:

Safety standard applied EN62368 -1: 2014

EN62311: 2008

EMC standard applied

EN55032: 2012

EN55024: 2010

EN61000-3-2: 2014

EN61000-3-3: 2013



To this effect, I declare that all radio test series have been carried out.

Full name: Laurent Godard,

Title: R&D Director

Date: January 4, 2022

Signature:

EUROPE - Norway Only: This product is designed for an IT power system with phase-to-phase voltage of 230 V. Earth grounding is via the polarized, 3-wire power cord.

FI: "Laite on liitettävä suojamaadoitus koskettimilla varustettuun pistorasiaan"

SE: "Apparaten skall anslutas till jordat uttag"

NO: "Apparatet må tilkoples jordet stikkontakt"

DK: "Apparatets stikprop skal tilsluttes en stikkontakt med jord, som giver forbindelse til stikpropens jord".

FCC Federal Communications Commission notice

Radio frequency interference in the United States



The KM2000B model complies with the following specification: FCC Part 15, Subpart A, Section 15.107(a) and Section 15.109(a) Class B Digital device

Additional information:

This equipment has been tested and found to comply with the limits for a Class B digital device, pursuant to part 15 of the FCC Rules. These limits are designed to provide reasonable protection against harmful interference in a residential installation. This equipment generates, uses and can radiate radio frequency energy and, if not installed and used in accordance with the instructions, may cause harmful interference to radio communications. However, there is no guarantee that interference will not occur in a particular installation. If this equipment does cause harmful interference to radio or television reception, which can be determined by turning the equipment off and on, the user is encouraged to try the following measures:

- Reorient or relocate the receiving antenna.
- Move the equipment away from the radio or television.
- Connect the equipment to a circuit other than that to which the receiver is connected.
- Consult the supplier or an experienced radio/TV technician.

Use of a shielded twisted pair cable is necessary to comply with the restrictions laid down by part 15 of the FCC Rules for Class B digital devices.

Pursuant to Part 15.21 of the FCC Rules, any changes or modifications made to this equipment without the express, written consent of the company Evolis may cause harmful interference and void the FCC authorization to operate this equipment.

We recommend keeping a distance of 20 cm between the user and the RFID module when it is in operation.

This device is compliant with the RSS of Industry Canada applicable to radio devices exempt from licensing. Operation is permitted under the following two conditions: (1) The device must not cause jamming and (2) the device user must accept any radio-electrical jamming it experiences, even if this comprises its operation.

Japanese radio frequency interference (VCCI)

This equipment is Class B information technology equipment based on the rules laid down by the Voluntary Control Council For Interference by Information Technology Equipment (VCCI). Its use in or close to a residential area may cause radio interference. If this occurs, you must take appropriate steps.



この装置は、情報処理装置等電波障害自主規制協議会（VCCI）の基準に基づくクラスB情報技術装置です。この装置は、家庭環境で使用することを目的としていますが、この装置がラジオやテレビジョン受信機に近接して使用されると、受信障害を引き起こすことがあります。取扱説明書に従って正しい取り扱いをして下さい。



이 기기는 업무용(A급) 전자파적합기기로서 판매자 또는 사용자는 이 점을 주의하시기 바라며, 가정외의 지역에서 사용하는 것을 목적으로 합니다.